

SERIES 01 THERMOSWITCH®

17000, 18000, 47000, 48000 Temperature Controllers
and 11000, 80016 Protective Wells

**FENWAL
CONTROLS**

F-01-020
March 2021

FEATURES

- Fast response
- Close control
- Extreme sensitivity
- Vibration resistance
- Adjustable
- Narrow Differential
- No Power Supply Required
- Stainless Steel Shell

APPLICATIONS

- Hydraulic Laminating Presses
- Livestock Watering Fountains
- Label Adhesive Applications
- Paint Drying Equipment
- Hot Stamp Printers
- Deep Fat Fryers
- Textile Platens

DESCRIPTION

THERMOSWITCH® controllers control temperatures as low as -100°F (-73°C) and as high as 600°F (316°C) with the proven dependability of over 75 years of service to satisfied customers.

PRINCIPLE OF OPERATION

The THERMOSWITCH® controller is a strut-and-tube type thermostat comprised of two basic parts: the outer shell, made of high-expanding stainless steel and the strut assembly, made of low-expanding metal.

A pair of electrical contacts is mounted on the strut assembly and installed in the shell under tension or compression.

Since each end of the strut assembly is mechanically connected to the ends of the shell, a net change of force is produced on the strut assembly as the shell expands or contracts with changing temperature. The temperature at which the contacts “make” or “break” can be regulated by a temperature adjusting sleeve.

AGENCY CERTIFICATIONS



Recognized under the Components Program of Underwriters Laboratories, Inc. (XAPX2)



Underwriters Laboratories Listed (XAPX)



Certified by Canadian Standards Association (Class 481302)
CSA File No. LR7378



BSI Test Report No. 8620513 in compliance with applicable clauses of EN 60730-1: 2000+A2:2008 and EN60730-2-9: 2010 for temperature controlling devices

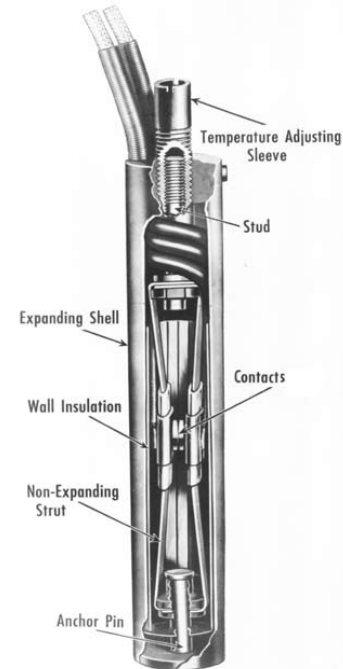

This adaptation of the differential-expansion principle gives several important control advantages:

- **Fast Response** - The outer shell of the THERMOSWITCH® is an active sensing element, and not merely a housing, response to temperature change is almost instantaneous.
- **Close Control** - The controller's shell and strut arrangement has “anticipation” characteristics which substantially reduce the amount of overshoot and undershoot during conditions of rapid temperature change. Anticipation is produced by an inherent time lag between the shell and struts, which causes the shell to “lead” the struts by an interval that varies with the rate of temperature change. With rapid temperature rise, the shell exerts a larger net force on the struts and tends to pull them apart sooner than if the temperature were rising slowly. The result is several degrees or more of anticipation which helps produce closer control.
- **Extreme Sensitivity** - The strut and contact operates by slow make and break. This means that every temperature change, no matter how small, causes a corresponding change in the space between the electrical contacts. Therefore, contact action can be produced by a very small temperature change, which accounts for the THERMOSWITCH® controller's excellent resolution sensitivity of 0.1°F (0.05°C).
- **Vibration Resistance** - Since the strut assembly is assembled under tension or compression, a properly installed unit has excellent vibration resistance and will provide great control under difficult physical conditions.
- **Agency Approved** - Various models are listed Underwriters Laboratories (UL) and certified by the Canadian Standards Association (CSA) and compliance with applicable European norms for acceptance in the EU under the CE marking scheme. Contact manufacturer for specific approval details.

THERMOSWITCH® Controllers
STANDARD PRODUCTS

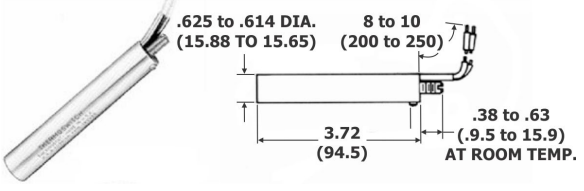
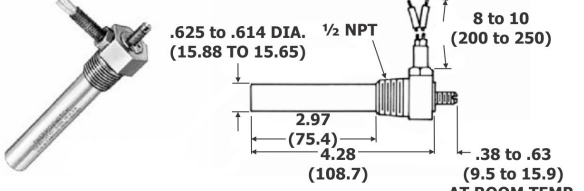
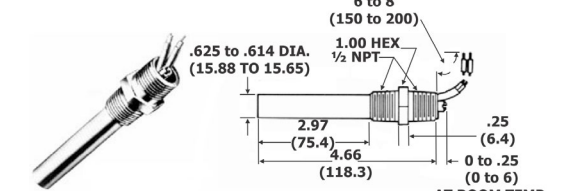
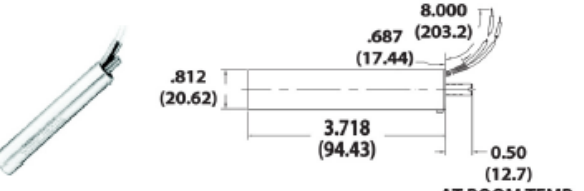
Thermoswitch® Unit Type Dimension Inches (mm) for reference only	Description	Catalog Numbers
 <p>.625 to .614 DIA. (15.88 TO 15.65) 8 to 10 (200 to 250) 3.72 (94.5) .38 to .63 (9.5 to 15.9) AT ROOM TEMP.</p>	<p>Cartridge Head The basic element of all THERMOSWITCH® controllers. Has all the desirable features of the ideal thermostat - high sensitivity, wide adjustment range, small size, rugged construction, vibration resistance, and low cost. The unit can be inserted into a .625 in. (15.88 mm) reamed hole.</p>	01-017002-000 01-017023-000 01-047002-000 01-047023-000
 <p>.625 to .614 DIA. (15.88 TO 15.65) 1/2 NPT 8 to 10 (200 to 250) 2.97 (75.4) 4.28 (108.7) .38 to .63 (9.5 to 15.9) AT ROOM TEMP.</p>	<p>Hex Head Has all the features of the Cartridge type plus the addition of a male pipe thread for mounting.</p>	01-017102-000 01-017123-000 01-017102-020 01-047102-000
 <p>.625 to .614 DIA. (15.88 TO 15.65) 6 to 8 (150 to 200) 1.00 HEX 1/2 NPT 2.97 (75.4) 4.66 (118.3) .25 (6.4) 0 to .25 (0 to 6) AT ROOM TEMP.</p>	<p>Coupling Head The Coupling Head type has a hexagonal mounting section with male pipe threads at each end. This unit may be directly attached to electrical conduit.</p>	01-018002-000 01-018023-000 01-018002-021 01-018023-007 01-180020-029
 <p>8.000 (203.2) .687 (17.44) .812 (20.62) 3.718 (94.43) 0.50 (12.7) AT ROOM TEMP.</p>	<p>Jumbo Thermoswitch Available in Cartridge Head and Coupling Head</p>	01-017052-000 (Cartridge) 01-018052-000 (Coupling)

LEGACY PRODUCTS – Contact Fenwal Controls for more details and availability.

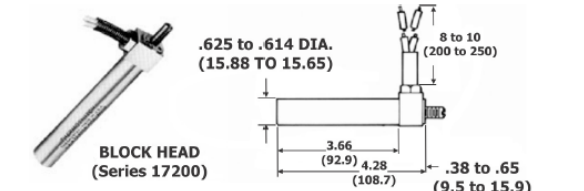
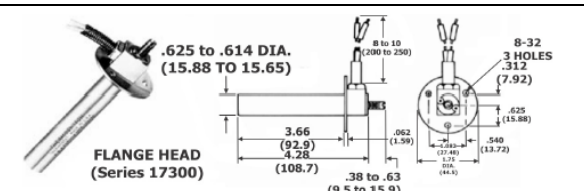
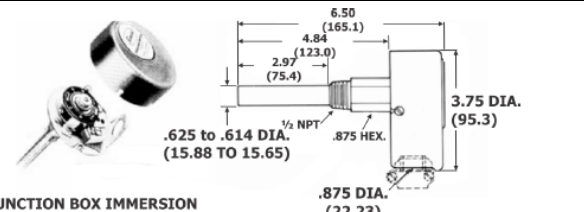
 <p>BLOCK HEAD (Series 17200) .625 to .614 DIA. (15.88 TO 15.65) 8 to 10 (200 to 250) 3.66 (92.9) 4.28 (108.7) .38 to .65 (9.5 to 15.9) AT ROOM TEMP.</p>	<p>Block Head This unit has the same mounting as the Cartridge type but is designed so modifications may be included. It also can be inserted into a .625 in. (15.88 mm) reamed hole.</p>	01-017202-000 01-017223-000
 <p>FLANGE HEAD (Series 17300) .625 to .614 DIA. (15.88 TO 15.65) 8 to 10 (200 to 250) 3 HOLES .312 (7.92) .625 (15.88) .540 (13.72) .062 (1.59) .38 to .63 (9.5 to 15.9) AT ROOM TEMP.</p>	<p>Flange Block Head Has all the features of the Block Head type except a mounting flange has been provided.</p>	01-017302-000 01-017323-000
 <p>JUNCTION BOX IMMERSION (Series 17800) 6.50 (165.1) 4.84 (123.0) 2.97 (75.4) .875 HEX. 3.75 DIA. (95.3) .625 to .614 DIA. (15.88 TO 15.65) 1/2 NPT .875 DIA. (22.23) OPENINGS</p>	<p>Junction Box Head Has electric conduit junction box containing terminal block and temperature adjusting dial and knob. Extended hexagonal section with pipe thread permits easy mounting into tapped hole of boss, immersing shell into fluid medium to be controlled.</p>	01-017802-000 01-017823-000

PRODUCT SPECIFICATION

	Catalog Number	Contact Operation on Temp. Rise	Material	Agency Listing	Temperature Range	Extreme Temperature Range (Max 1 Hour)	Current Ratings	Approx. Degrees per Revolution	Weight
Cartridge Head	01-017002-000	Opens	Brass Head Stainless Shell (300 SS)	-100 to +400°F -73 to +204°C	-100 to +600°F -73 to +316°C	100°F/55°C above set point	AC 10 amp 120 volts 5 amp 240 volts (non-inductive) DC .5 amp 24 volts	110°F/60°C	2.5 oz
	01-017023-000	Closes		700°F/370°C		100°F/55°C			
	01-047002-000	Opens		-100 to +500°F -73 to 260°C		100°F/55°C above set point		110°F/60°C	
	01-047023-000	Closes		700°F/370°C		100°F/55°C			
Hex Head	01-017102-000	Opens	Brass Head Stainless Shell (300 SS)	-100 to +400°F -73 to +204°C	-100 to +600°F -73 to +316°C	100°F/55°C above set point		100°F/55°C	5 oz
	01-017123-000	Closes	Stainless Head & Shell (316 SS)	-100 to +400°F -73 to +204°C		700°F/370°C		100°F/55°C	6 oz
	01-017102-020	Opens				100°F/55°C above set point		100°F/55°C	
	01-047102-000	Opens	Brass Head Stainless Shell (300 SS)	-100 to +500°F -73 to 260°C		100°F/55°C above set point		100°F/55°C	5 oz
Coupling Head	01-018002-000	Opens	Brass Head Stainless Shell (300 SS)	-100 to +400°F -73 to +204°C	-100 to +600°F -73 to +316°C	100°F/55°C above set point	DC .5 amp 24 volts	100°F/55°C	5 oz
	01-018023-000	Closes	Stainless Head & Shell (316 SS)	-100 to +400°F -73 to +204°C		700°F/370°C		100°F/55°C	
	01-018002-021	Opens				100°F/55°C above set point		100°F/55°C	6 oz
	01-018023-007	Closes				700°F/370°C		100°F/55°C	
	01-180020-029	Opens	-100 to +500°F -73 to 260°C	100°F/55°C above set point		100°F/55°C			
Jumbo	01-017052-000	Opens	Brass Head Stainless Shell (300 SS)	-100 to +400°F -73 to +204°C	-100 to +600°F -73 to +316°C	100°F/55°C above set point	AC 25 amp 120 volts 12.5 amps 240 volts	110°F/60°C	4 oz
	01-018052-000		100°F/55°C	7 oz					

APPLICATION HINTS – Contact Protection

Capacitors are not needed under average conditions. For smoother control of small loads (below 1/10th the controller rating or to prevent contact bounce due to vibration) use capacitance in μF of 0.28 divided by line voltage.

Note: Capacitors should be rated a minimum of 600 volts for 120 volt circuits and a minimum of 1000 volts for 240 volt circuit.

RATINGS

Unless otherwise specified, all rating apply to non-inductive loads, such as heaters or resistors. Tungsten filament lamps have an inrush of 10 to 15 times the steady state current. Do not exceed switch rating at any time.

TEMPERATURE OFFSET DUE TO PRESSURE (Approx. Only)

Pressure does have an impact to the calibration temperature. Utilize the Pressure Table to adjust for the offset.

Capacitance Table

Voltage	Service	Capacitance (μF)
120 VAC	Resistance	None Required
240 VAC	Resistance	0.1
120 or 240 VAC	Relays	0.001 to 0.01
15 to 25 VAC	Relays	0.02
120 or 240 VAC	Motors	Use Relay

Pressure Table

Pressure PSI	Set Point Offset
100	+3°F / 2°C
200	+6°F / 3°C
300	+9°F / 5°C
400	+12°F / 7°C
500	+15°F / 8°C
Collapsing pressure 3,500 psi at room temperature.	

MODIFICATIONS

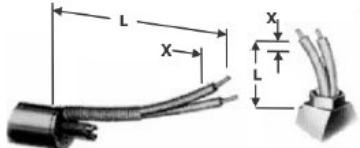
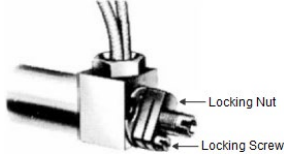
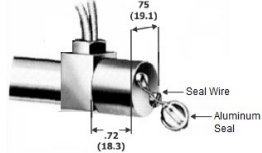
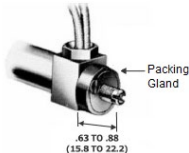
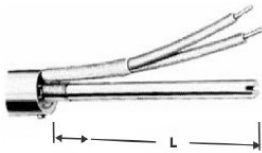
<p>Special Marking (Mod 1) Special Marking may be at points A or B and is limited to the space available. Location of marking is at discretion of Fenwal and in line of existing marking process.</p>	
<p>Extended Lead Wires (Mod 2) Lead wires may be extended to any length. Length (L) is specified as the portion of lead wire outside the Thermoswitch Unit. Special lead wire stripping may also be obtained by specifying length shown as dimension "X".</p>	
<p>Factory Temperature Setting (Mod 3) The unit may be preset at Fenwal Controls to any temperature within its listed range to a minimum of 32°F (0°C). Unless this modification is specified, units are preset at approximately 75°F (25°C). Modification 4 is recommended when ordering a factory set unit to preclude a possible shift in set point do to mishandling.</p>	
<p>Temperature Locking Device (Mod 4) A restraining device may be added to secure the temperature adjustment sleeve after calibration. This modification deters tampering with the setting. It also minimizes the possibility of a shift in calibration due to vibration.</p>	
<p>Tamper Proof Cap (Mod 5) A tamper-proof cap can be furnished to prevent tampering with a THERMOSWITCH® controller equipped with Modification 4 above.</p>	
<p>Moisture Resistant Seal (Mod 8) Under certain conditions where there is excessive moisture or vapor, a moisture resistant seal may be added to protect the interior of the THERMOSWITCH® controller.</p>	
<p>Extended Temperature Adjusting Sleeve (Mod 14) Adjustment sleeve extensions are available only in multiples of one inch. While ordering, the length specified is the "extended by" length "L", up to 15 inches. For example, if the standard adjusting sleeve length for the controller ordered is 1/2 inch, and a 4 inch extension is ordered, the overall length will be 4-1/2 inches.</p>	
<p>Extended Shell (Special Feature 31) In applications where a standard THERMOSWITCH® controller is too short to reach the medium to be controlled, the shell length may be extended. Extension must be ordered in increments of 1 inch beyond standard length up to 18 inches.</p>	
<p>Notes:</p> <ul style="list-style-type: none"> • Certain combinations of modifications can not be combined. 4 & 8, 5 & 14. • Minimum ordering quantities may apply. 	

HOW TO ORDER - THERMOSWITCH®

1. Select model controller from data on page 2 and 3.
2. Provide catalog number when ordering.
3. Provide request for modification when ordering.

Note: A variation of the catalog number may be provided based on modifications requested.

Note: Consult factory for parts availability and minimum order quantity requirements.

PROTECTIVE WELLS – Series 34-11000

In many applications involving liquid and gases, the use of a well is recommended. When the removal of a hex or coupling head THERMOSWITCH® controller would require draining of the container in which it is inserted, the use of a well assembly permits removal of the controller at any time without other disturbances. When surrounding ambients are subject to extreme changes thus affecting THERMOSWITCH® control, the well makes it possible to insert the THERMOSWITCH® controller completely into the medium being controlled thereby eliminating these ambient temperature effects or “head effect”.

A well offers protection in applications where fluids have a corrosive effect on the THERMOSWITCH® controller.

WELLS – For use with 170XX 5/8” Diameter Cartridge THERMOSWITCH® Controllers

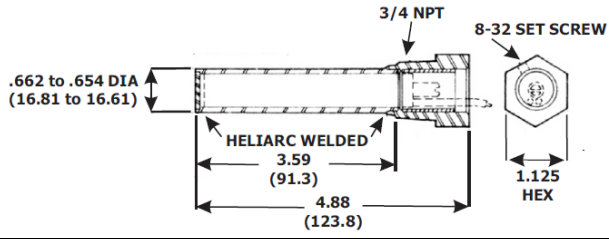
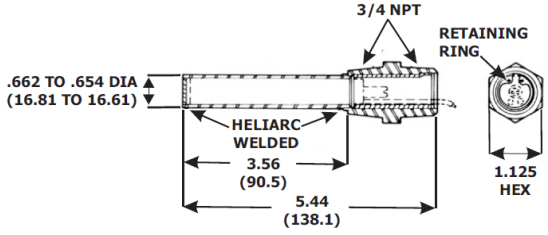
Well Type	Description
	<p>Catalog No. 34-011201-000 Hex Head Well (321 Stainless Steel Well & Head) Applicable Modifications Mod 1 Special Marking SF 31A Extended Shell Approximate weight is 4 oz Pressure Ratings: 100 psi at -100°F to +250°F 60 psi at 600°F</p>
	<p>Catalog No. 34-011204-000 Coupling Head Well (321 Stainless Steel Well & Head) Applicable Modifications Mod 1 Special Marking SF 31A Extended Shell Approximate weight is 5 oz Pressure Ratings: 100 psi at -100°F to +250°F 60 psi at 600°F</p>

Note: Certain gases or liquids (including water at elevated temperatures) could be corrosive and/or cause electrolytic action, which could severely shorten the life of the controller. Where corrosion or electrolysis is suspect, the use of stainless steel heliarc welded thermowells or various platings or coatings may increase controller life. The rate of corrosion or electrolysis is influenced by a great many system parameters such as chemical makeup and temperature of the solution, stray electric currents, etc. Consult the supplier of your chemicals or Fenwal for suggestions.

In addition, use a well to protect the THERMOSWITCH® controller from external forces or blows which could affect its operation.

Modifications

SF 31A - Extended Well Assembly

The shell of the well assembly may be extended in increments of 1 in (2.5 cm) to a maximum of 18 in (46 cm). The THERMOSWITCH® Unit is also extended (S.F. 31) an equal amount.

Example: A well extended by 9 inches has a “C” dimension of 12.56 inches. Minimum order quantities apply.

When special features are specified, THERMOSWITCH® controllers are assigned a special catalog number. As a result, THERMOSWITCH® controllers as received may bear a different catalog number than the one specified on the customer order.

PROTECTIVE WELLS FOR HAZARDOUS LOCATIONS Series 34-80016

The 34-080016-004 is an "Explosion Proof" well assembly designed to meet the requirements of Class I, Group D and Class II, Groups E, F, and G. Division 1 and 2 locations. The desired THERMOSWITCH controller must be ordered separately. The assembly is UL listed and CSA certified for these specific hazardous location categories.

The sensing element, which is a cartridge-type THERMOSWITCH® Unit, is seated in the well assembly and held in place by a snap ring. The well assembly, in turn, is threaded into the explosion-proof junction box, giving protection to the controller.

SPECIFICATIONS

Dimensions (Refer to photo)

A = 8.37 ± 0.25 in (212.6 ± 6 mm)

B = 4.50 ± 0.10 in (114.3 ± 2.5 mm)

C = 3.60 ± 0.06 in (91.5 ± 1.5 mm)

D = 0.656 + 0.004, -0 in (16.66 +0.10. -0mm)

Well Assembly Pressure Ratings

100 psi at 250°F (690kPa at 120°C)

60 psi at 500°F (415 kPa at 260°C)

Well Assembly Material

Type 321 Stainless Steel

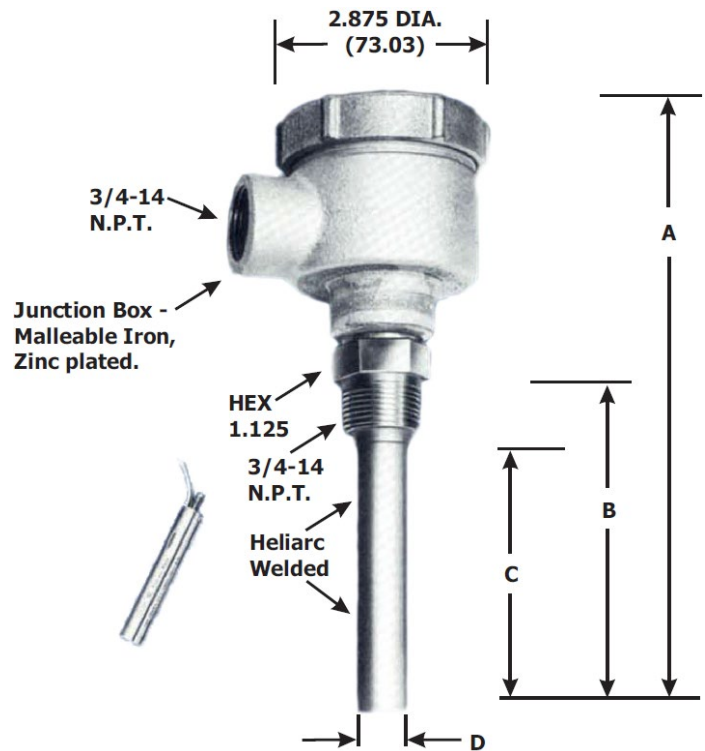

Note: Only models 34-047002-XXX and 34-047023-XXX may be inserted in this well.

HOW TO ORDER – PROTECTIVE WELLS

1. Protective Wells and the THERMOSWITCH assembly must be ordered separately.
2. Select model controller from data on page 2 and 3 with modifications on page 4 and well on page 5 and 6.
3. Modifications, if desired, require detailed explanation.

Example: Well 34-080016-004 with THERMOSWITCH 01-047002-000 with Mod 3 set to 155F and Mod 4 Temperature Locking Device.

Note: Shell length may change for protective wells with change in THERMOSWITCH® shell length.

Note: Consult factory for parts availability and minimum order quantity requirements.

EXPORT INFORMATION (USA)

Jurisdiction: EAR

ECCN: EAR99

This document contains technology subject to the EAR. Export, reexport, or transfer without required authorization is prohibited

This literature is provided for informational purposes only. KIDDE-FENWAL, INC. assumes no responsibility for the product's suitability for a particular application. The product must be properly applied to work correctly. If you need more information on this product, or if you have a particular problem or question, contact KIDDE-FENWAL, INC., Ashland, MA 01721.

All trademarks are property of their respective owners



LICO Mechatronic Kft.

Raba u. 4.
H-2030 Erd, Hungary
Email: sales@lico.hu / iroda@lico.hu
Tel: +36 23 520 138

LICO Electronics GmbH

Klederinger Strasse 31
A-2320 Kledering, Austria
E-mail: sales@lico.at / office@lico.at
Tel.: +43 1 706 4300

www.fenwal-direct.eu
www.prevent-a-fire.eu