

Platon Flow Alarms For Glass VA

DS1120



www.platon-direct.eu

FEATURES

- Detects rise or drop of a specified level of flow
- Self-calibrates sensitivity to accommodate various tube transparency
- Detects conditions that may adversely affect reliability
- Status indicator
- Adjustable over full range of flow tube
- Suitable for normal (NG/NGX) or miniature (LG/LGX) flowmeters
- Open drain output that can drive standard logic circuits
- Optional mains interface relay module



DESCRIPTION

Platon Floscan sensors use an infra-red beam across the glass flowtube of a Variable Area (VA) flowmeter. Passage of the float between the sensor arms is detected, and logic within the electronics determines whether the float is above or below the sensor position. Electronics inside the sensor module gives an open drain transistor output, suitable for external logic circuits.

Suitable for all gas flows, and liquid flows where the float is visible, the sensor is clipped to the back of the flowmeter frame, typically on a Platon NG/NGX Series (normal 100mm scale) or LG/LGX series (miniature 30mm scale) VA meter.

Movement up and down the frame allows the sensor to provide a flow alarm at any point on the tube scale, as required. The sensor can also be supplied on Platon GU or SGUV style flowmeters.

The optional mains interface and relay module is used to provide the DC power needed to drive the sensor electronics, plus a SPCO 8 Amp mains relay output. This relay acts as a slave to the transistor output from the sensor module. Each Floscan relay module has two output relays, and can be used to monitor two separate alarm sensors.



LICO Electronics GmbH K
lederinger Strasse 31
A-2320 Kledering, Austria
E-mail: sales@lico.at | office@lico.at
Tel.: +43 1 706 4300

LICO Mechatronic Kft.
Raba u. 4.
H-2030 Erd, Hungary
Email: sales@lico.hu / sales@lico.at
Tel: +36 23 520 138

www.platon-direct.eu

Platon Flow Alarms For Glass VA

DS1120

www.platon-direct.eu



SPECIFICATION

Sensor Type	IR Beam break detection
Direction Logic	Position of float above/below sensor established on first detection of float after power up
Setting Position	Held by spring clip anywhere in flow tube operating range
Temperature	-5 to +50°C
Environment	IP44 with cable exit downwards
Dimensions	H22 x W61 x D33 mm 5mm space needed behind frame (spacer provided)
Sensor Cable	2m, 3-core screened
Cable Functions	Red - positive supply Black - 0V (common) White - transistor output
Supply	9V nominal, 7-10Vdc range 20-50mA range - depending on tube transparency
Output	Open circuit: no-alarm, conducting: alarm; Type: open drain, max voltage: 36V, max current: 25mA, ON resistance: <120Ω, OFF resistance: >20MΩ
Switch Points	For falling float: base of float at centre of height of sensor. For rising float, switching occurs when top of float passes centre of height of sensor.
Speed of float	Up to 31m/s
Approvals	EMC Directive 2014/30/EU and UK Electromagnetic Compatibility Regulations 2016 No. 1091
Order Code	???????

PRINCIPLE OF ORIENTATION

The Floscan sensor module positions an infra-red detector beam accurately side to side across the flowtube, at a pre-set level. The beam is transmitted through the flowmeter cover and glass tube walls, but is broken by the presence of the float. Two IR sensitive detectors, one above the other, monitor the passage of the float shadow: direction of float travel is determined by the order in which the detectors emerge from the shadow. This allows the sensor to remember whether the float is above or below the sensor position.

Because the NGX/NG/LGX/LG series frames are compact units, the Floscan module is designed to be mounted externally. Alignment is maintained by connecting the two transmitter/receiver lobes together around the back of the flowmeter frame, where the whole unit clips into the extrusion grooves. For panel mounted flowmeters, this means the frame must be spaced forwards from the panel by approx 5mm – spacer provided.

COMPATIBILITY

1. Frames

All standard GIR sensors are supplied with a fitting kit suitable for use on Platon NG, LG, NGX, or LGX style frames. (See Data sheet DS1112 or DS1115) The sensor can be supplied fitted within Platon GU or SGUV style housings.

2. Flow Fluid

GIR sensors are supplied set up for the flowtube size specified and either liquid or gas as the flowing medium. The sensors are not normally interchangeable between different sized flowtubes.

3. Flow Scales

For size 1 and 2 flowtubes, the flow scale artwork serial number (eg CA 141002) must be issue C or later (first digit). Otherwise the scale marks may interfere with the infra-red beam. For size 3 flowtubes, GIR sensors will work correctly on all previously supplied scale artworks.

Consult the sales office and specify flowtube and alarm sensor module together.

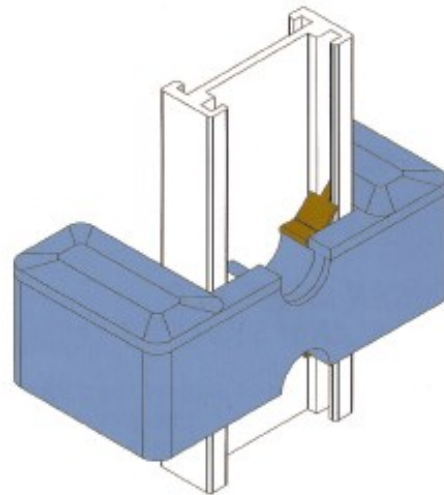

Floscan GIR sensor shown clipped into the back of the NGX/LGX/NG/LG Series Flowmeter Frame



LICO Electronics GmbH K
lederinger Strasse 31
A-2320 Kledering, Austria
E-mail: sales@lico.at | office@lico.at
Tel.: +43 1 706 4300

LICO Mechatronic Kft.
Raba u. 4.
H-2030 Erd, Hungary
Email: sales@lico.hu / sales@lico.at
Tel: +36 23 520 138

www.platon-direct.eu

Platon Flow Alarms For Glass VA

DS1120



www.platon-direct.eu

All GIR Flowscan sensors are supplied with a fitting kit of retaining spring and two spacers for panel mounting of NGX/LGX and NG/LG frames.

OPTION: MAINS INTERFACE RELAY MODULE

- SPCO relay output
- Mains AC or DC power
- LED indicators
- Can drive two sensors

The Floscan alarm optional mains power and slave relay output module is a DIN rail/surface mounted unit that provides DC power for one or two Floscan sensors.

Each sensor output drives a relay in the module, allowing external signalling via volt free contacts.

The two Floscan sensors can be high or low flow alarms (dictated by the sensor orientation), on the same flowmeter tube, or on separate flowmeters.

Relay status as well as set-up status are displayed by LED indicators.



START-UP LOGIC

On power-up, the sensor has no information as to whether the float is above or below the sensor. The output state is therefore indeterminate, and can represent high or low flow. Once the float has passed the sensor for the first time, the memory logic is triggered and the output validated.

EXTERNAL CONNECTIONS

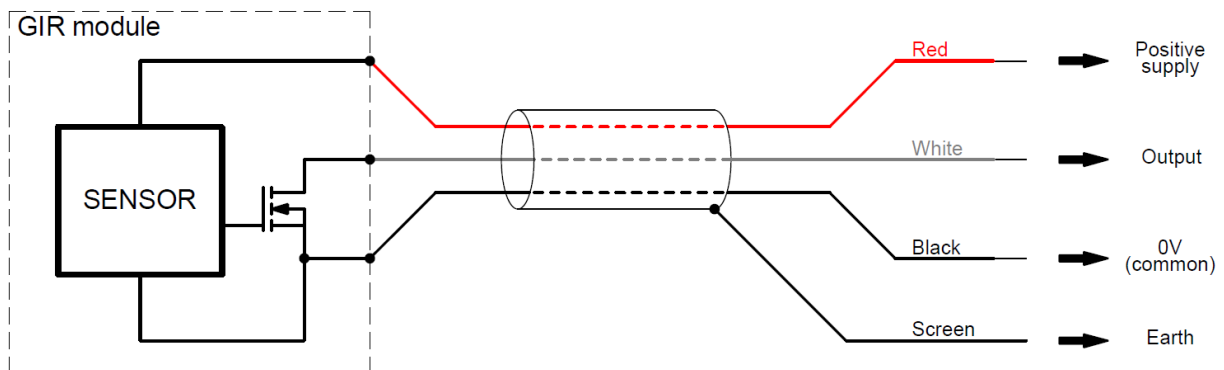

LICO Electronics GmbH K
lederinger Strasse 31
A-2320 Kledering, Austria
E-mail: sales@lico.at | office@lico.at
Tel.: +43 1 706 4300

LICO Mechatronic Kft.
Raba u. 4.
H-2030 Erd, Hungary
Email: sales@lico.hu / sales@lico.at
Tel: +36 23 520 138

www.platon-direct.eu

Platon Flow Alarms For Glass VA

DS1120

www.platon-direct.eu



SPECIFICATION

Mains Power Input	20-256Vac, 50/60Hz 24-370Vdc
Sensor Power Output	+9Vdc 100mA (suitable for GIR Alarm modules) +12Vdc 100mA (suitable for GMTXD transmitter)
Floscan Inputs	Two channels
Relay Outputs	Two 8A 250Vac maximum, SPCO
LED Indicators	Green - alarm ON (relays energised) Red - set-up procedure must be carried out Yellow - power on
Temperature	-5 to +50°C
Dimensions	H77 x W75 x D115 mm
Terminal Covers	When fitted over terminals protection rating IP20
Order Code	58384 Floscan Alarm module.

CONNECTIONS

E	Earth
SCR	Sensor Cable Screen (the end of the cable shield should be as short as possible)
S1	Sensor 1 input
S2	Sensor 2 input
0V	Sensor supply and output common
+9V	Sensor supply
L	Live power
N	Neutral power
CH1	Relay output from Sensor 1: Common, Normally Closed, Normally Open
CH2	Relay output from Sensor 2: Common, Normally Closed, Normally Open

Every effort has been made during the preparation of this document to ensure the accuracy of statements and specifications. However, we do not accept liability for damage, injury, loss or expense caused by errors or omissions made. We reserve the right to withdraw or amend products or documentation without notice.



03HWAR0410



LICO Electronics GmbH K
lederinger Strasse 31
A-2320 Kledering, Austria
E-mail: sales@lico.at | office@lico.at
Tel.: +43 1 706 4300

LICO Mechatronic Kft.
Raba u. 4.
H-2030 Erd, Hungary
Email: sales@lico.hu / sales@lico.at
Tel: +36 23 520 138

www.platon-direct.eu