

Platon Armoured Purgemeter

DS1210



www.platon-direct.eu



Features:

- For high integrity of high pressure duty
- Suitable for flush panel mounting
- Scaled for specific process conditions

PLATON METAL TUBE PURGE FLOWMETER—TYPES API, APT, APV

Armoured Purgemeters are direct reading flowmeters for liquid or gas measurement on small lines. Using a stainless steel tapered tube to create a variable area flowmeter, the magnetically coupled pointer shows flowrate on an external scale. Armoured purgemeters are chosen where the higher integrity offered by a metal flow tube is important, or where conventional glass flow tubes are not allowed in the process. Ideal for flow monitoring in purging, mixing or sampling systems, the meters are available with inline (API) or rear facing (APT) screwed connections.

For fine flow rate adjustment, the APV model has an integral multi-turn needle valve. Scales are individually produced to show the actual fluid flow for the process fluids and conditions relevant.

The units are suitable for flush mounting in a control panel, using a simple mounting kit.



LICO Electronics GmbH K
lederinger Strasse 31
A-2320 Kledering, Austria
E-mail: sales@lico.at | office@lico.at
Tel.: +43 1 706 4300

LICO Mechatronic Kft.
Raba u. 4.
H-2030 Erd, Hungary
Email: sales@lico.hu / sales@lico.at
Tel: +36 23 520 138

www.platon-direct.eu

Platon Armoured Purgemeter

DS1210

OPERATING PRINCIPLE

The VA meter principle used in the Armoured Purgemeter measures the position of a float in a precision machined tapered tube. The float rises with the fluid flow up the taper until the upthrust balances the float weight. A magnet, sealed within the float casing, drives the external pointer over a full 90° rotation against a scale printed in actual process flow units.

The meter housing secures the different styles of end block in place, which provide the process connections: between these the flow tube is O-ring sealed onto the end block.

Standard units require no electrical connection.

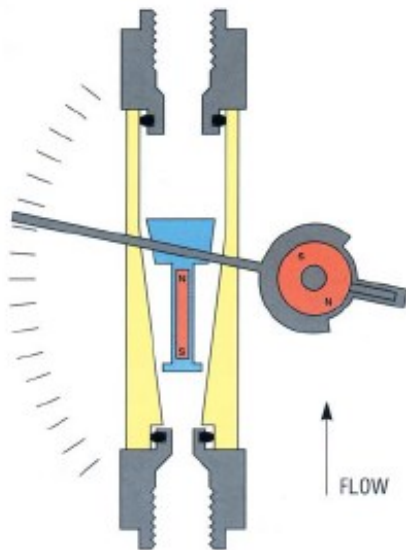

SPECIFICATION

Materials	Flow tube and end blocks – 316 stainless steel Float – stainless steel for liquids, dural for gases O-ring seals – Viton Flow control valve – 316 stainless steel
Meter Housing	Aluminium, black anodised, polycarbonate window protection IP65
Scales	Specific scale produced to give actual flow rate in engineering units for quoted process conditions. Standard air and water capacity quoted in flow tables.
Accuracy	VDE/VDI 3513 Class 4 standard
Repeatability	± 0.5% FSD
Fluid Temperature	20°C to +150°C
Fluid Pressure	150 bar max (non valved models API, APT) 40 bar max (model APV with valve)
Connections	1/4" NPT female

Special versions are available with improved accuracy or built to withstand high temperatures or pressures, or with alternative process connections or from alternative materials.



API



APV



APT



LICO Electronics GmbH K
lederinger Strasse 31
A-2320 Kledering, Austria
E-mail: sales@lico.at | office@lico.at
Tel.: +43 1 706 4300

LICO Mechatronic Kft.
Raba u. 4.
H-2030 Erd, Hungary
Email: sales@lico.hu / sales@lico.at
Tel: +36 23 520 138

www.platon-direct.eu

Platon Armoured Purgemeter

DS1210

ORDER CODE

Typical Model

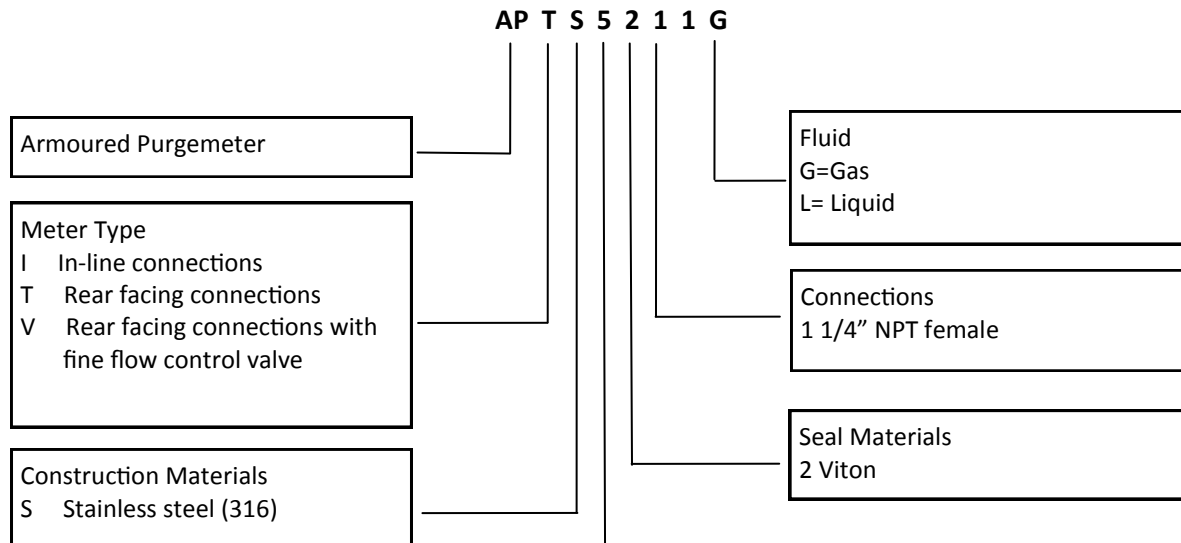

FLOW RANGES

Model Code	Water flow (20°C)	Air flow (ATP, 1013 bar at 20°C)	Typical pressure drop (mBar) at max flow	
	L/hr	L/hr	Water	Air
3	1-10	25-250	3	2
4	2-16	40-400	6	3
5	3-25	60-600	8	6
6	4-40	100-1000	19	6
7	6-60	160-1600	24	8

NOTE:

Scales are custom made to show actual process flow, so ranges may differ.

Please specify fluid density (SG), viscosity and process pressure/temperature, plus normal flowrate, to allow model selection.

Pressure drops quoted are typical for Model API at maximum flow.



LICO Electronics GmbH K
 lederinger Strasse 31
 A-2320 Kledering, Austria
 E-mail: sales@lico.at | office@lico.at
 Tel.: +43 1 706 4300

LICO Mechatronic Kft.
 Raba u. 4.
 H-2030 Erd, Hungary
 Email: sales@lico.hu / sales@lico.at
 Tel: +36 23 520 138

www.platon-direct.eu

Platon Armoured Purgemeter

DS1210

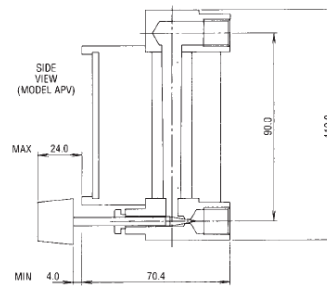
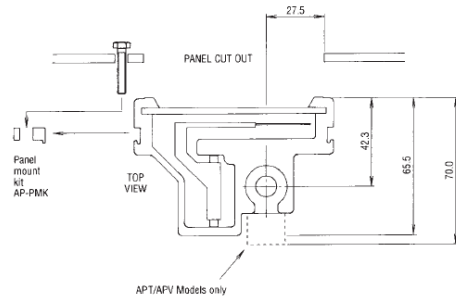
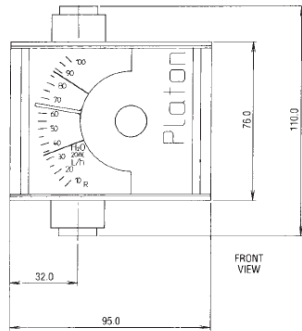

DIMENSIONS

PANEL CUTOUT

(Front view)

4 Holes $\varnothing 4.1$

Model APV
Hole $\varnothing 8.0$ for
Valve spindle

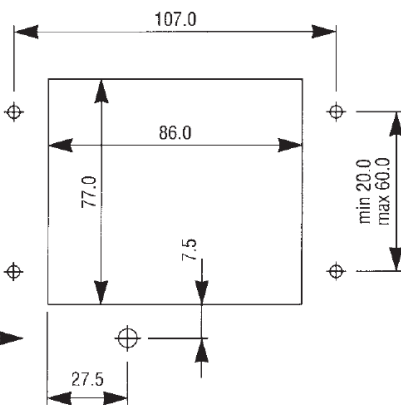

Purge Model APV
Mounted in control panel

Every effort has been made during the preparation of this document to ensure the accuracy of statements and specifications. However, we do not accept liability for damage, injury, loss or expense caused by errors or omissions made. We reserve the right to withdraw or amend products or documentation without notice.



04HWAR0410



LICO Electronics GmbH K
lederinger Strasse 31
A-2320 Kledering, Austria
E-mail: sales@lico.at | office@lico.at
Tel.: +43 1 706 4300

LICO Mechatronic Kft.
Raba u. 4.
H-2030 Erd, Hungary
Email: sales@lico.hu / sales@lico.at
Tel: +36 23 520 138

www.platon-direct.eu