

Platon Gapmeter Type GU

INSTALLATION

1. Remove all packaging and check that the Float moves freely.
2. The instrument should be examined for any transit damage prior to installation.
3. Re-check that the instrument is suitable for the chosen application, ie Corrosion Resistance.
4. Select a location for the instrument to avoid:
 - a) Vapour condensation in instrument.
 - b) Settling out of sediment in instrument.
5. Include a bleed facility, if the process fluid is likely to freeze in the instrument.
6. Include a valved loop, if frequent instrument cleaning may be required.
7. The pipeline should be cleared of any foreign matter likely to inhibit instrument performance. A 50 micron filter should be fitted upstream of the meter, if particles larger than this might be present in the flow.
8. The upstream and downstream pipe bores should be the same nominal size as the instrument. Minimum straight pipe lengths of five diameters upstream and two diameters downstream are recommended.
9. Ensure the instrument is installed vertically in the pipe work with the direction of flow upwards.
10. Solenoid valves should NOT be used where they act directly on the instrument.
11. Avoid use of connections or pipe work at the instrument inlet, which will cause flow turbulence, likely to disturb the Float stability.
12. When using hazardous gases, it is advisable to remove the safety Grommet (item 13) and replace with suitable pipe work to vent off to a non-hazardous area.
13. When mounting on the front of a panel, ensure the Safety Grommet area is not obscured.
14. Read the top edge of the Float

MAINTENANCE

1. Recommended spares are shown with a double ring on Fig 2.
2. Spare Tube assemblies comprise of Tube, Float, top Float stop and bottom Float stop where applicable and are available by referring to the catalogue.

3. Please quote RM&C reference and/or your Purchase Order number, when requesting spares.
4. Refer to datasheets and order acknowledgement for instrument specification.

TUBE & O-RING REPLACEMENT

1. Unscrew 4x Screws and remove the Bezel (Ref Fig 1).
2. By pulling towards you, remove the plastic Wedge, located at the bottom of the Housing.
3. Slide the Tube downwards, towards the gap created by the removal of the plastic Wedge, until the bottom Insert is fully engaged in its End connector. Ensure that the top Insert and End connector remain engaged together.
4. Noting the Tube and Float orientation, tilt the top of the Tube towards you, until it is clear of the Insert, then pull upwards.
5. If the O-rings DO NOT require replacing, then jump to 11.
6. Remove both Inserts from their End connectors by pulling, noting which Insert came from which End connector. To aid with their removal, the plastic Wedge can now be used as a sliding Wedge.
7. Remove 2x old O-rings from each Insert.
8. Care should be taken that the new O-rings are not damaged when assembling them to the Inserts.
9. Moistening the O-rings with a suitable lubricant is advisable, such that when reassembling to the End connectors or Tube, the O-rings are not damaged.
10. As previously noted, push the Inserts back into the appropriate End connector, fully.
11. To replace the Tube, reverse steps 1-4, using steps 12 and 13, for guidance.
12. To aid engagement and reduce possibility of O-ring damage, rotate the Tube back and forth, whilst pushing the Tube and Insert together.
13. Once the Tube is located on the bottom Insert, use the plastic Wedge on the bottom Insert as a sliding Wedge to force the top Insert and Tube together.

Dimensions:	C3 -	GU
	C3/1 -	Panel Mounting
	C3/9 -	GU c/w Magnetic Alarm
	C3/10 -	GU c/w Single GIR Alarm

Fig 1

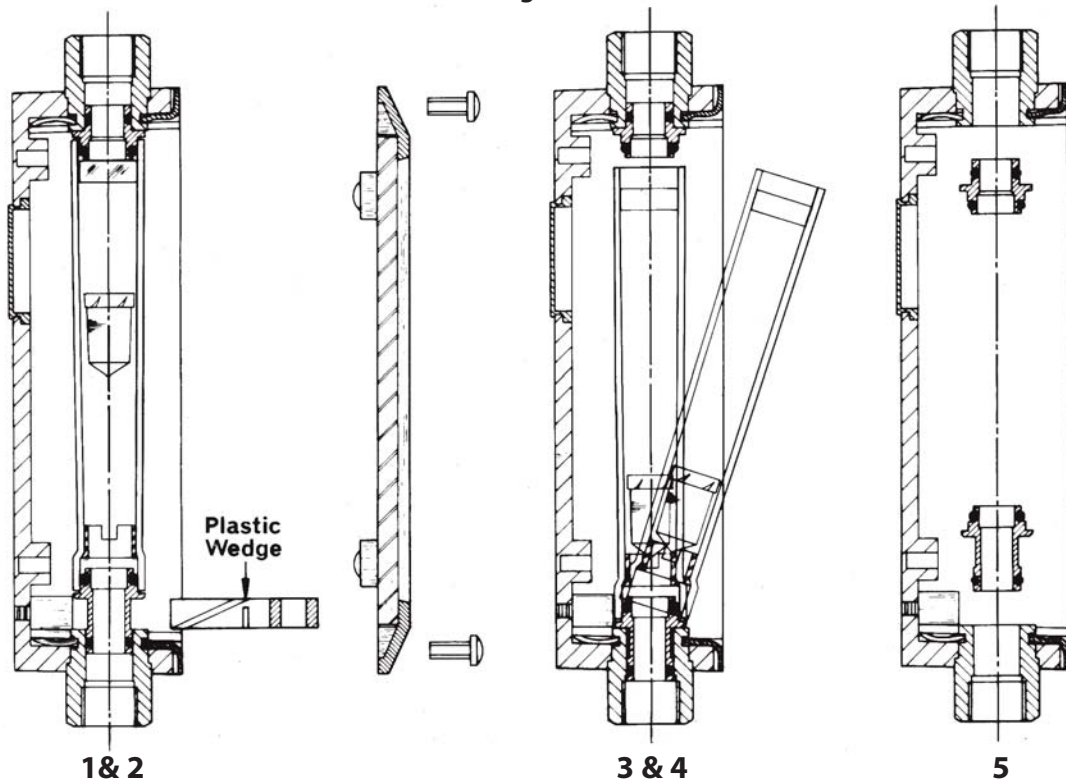
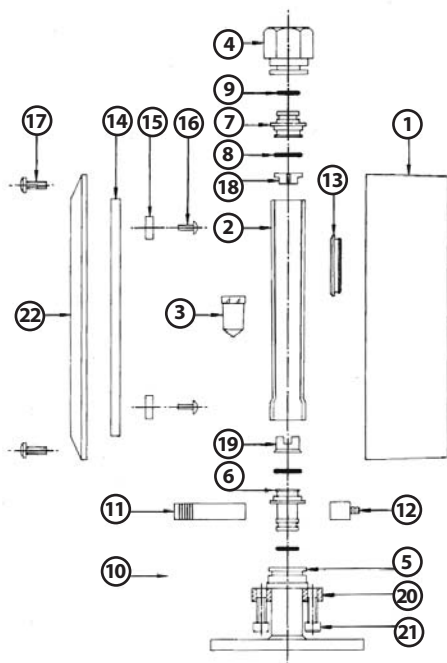

Fig 2



ITEM	DESCRIPTION	MATERIAL	QTY	
			GU	GUF
1	Housing	Alu Alloy	1	1
2	Tube	Glass or TPX	1	1
3	Float	Duralium or SS	1	1
4	Screwed Connector	SS or Brass	2	-
5	Flanged Connector	SS	-	2
6	Bottom Insert	SS or Brass	1	1
7	Top Insert	SS or Brass	1	1
8	O-ring	Viton or Nitrile	2	2
9	O-ring	Viton or Nitrile	2	2
10	Spring Clip	Spring Steel	2	2
11	Wedge	Kemetal	1	1
12	Wedge Support	Delrin	1	1
13	Grommet	Polypropylene	1	1
14	Window	Perspex	1	1
15	Button	Polypropylene	4	4
16	Fasteners	MS	4	4
17	Screws	MS	4	4
18	Top Float Stop	Polypropylene	1	1
19	Bottom Float Stop*	Polypropylene	1	-
20	Flange Clamp Ring	SS	-	2
21	Socket Cap Head Screws	SS	-	8
22	Bezel	Alu Alloy	1	1

* Size 1 & 10 only.
All Brass is Nickel Plated

Every effort has been made during the preparation of this document to ensure the accuracy of statements and specifications. However, we do not accept liability for damage, injury, loss or expense caused by errors or omissions made. We reserve the right to withdraw or amend products or documentation without notice.



LICO Electronics GmbH
 lederinger Strasse 31
 A-2320 Kledering, Austria
 E-mail: sales@lico.at | office@lico.at
 Tel.: +43 1 706 4300

LICO Mechatronic Kft.
 Raba u. 4.
 H-2030 Erd, Hungary
 Email: sales@lico.hu / sales@lico.at
 Tel: +36 23 520 138



www.mess-regeltechnik.at

www.platon-direct.eu