

Platon Gapmeter Type NG/LG

INSTALLATION

1. Remove all packing and check that the float moves freely.
2. Check that the float material is immune to corrosion and the seals resistant to solvent action of the process fluid.
3. Select the location of the flowmeter to void:
 - a) Condensation of vapour in the flowmeter.
 - b) Settling out of any sediment in the flowmeter.
4. Install in a valved loop, if frequent cleaning may be needed.
5. Arrange a bleed, if the process fluid is liable to freeze in the flowmeter.
6. Support connecting pipes so that the flowmeter is accurately vertical.
7. Avoid jets at entry or any other fitting causing turbulence likely to disturb float stability.
8. Read the top edge of the float.
9. When surface mounting the flowmeter, the 20mm ($\varnothing L$) in the backplate should be free from obstruction to allow the safety strip to operate correctly. For Panel cut out details see Fig 1.

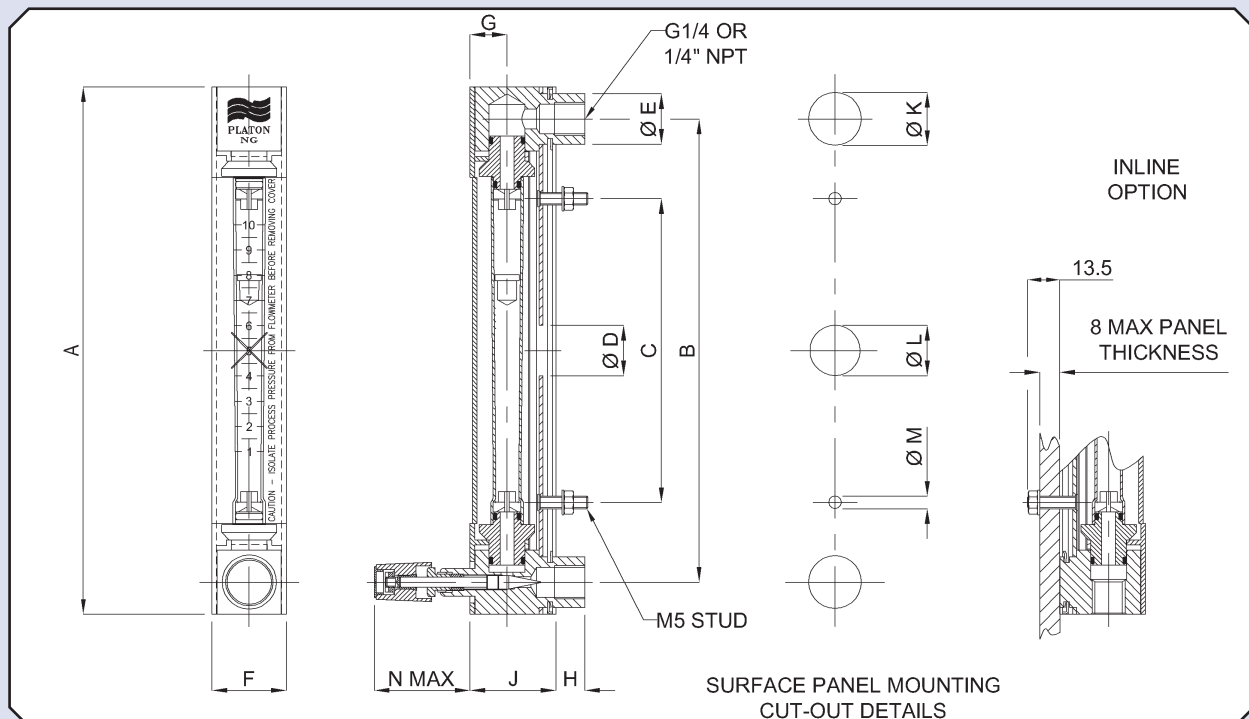

	A	B	C	ØD	ØE	F	G	H	J	ØK	ØL	ØM	N
NG	209.5	184	121	20	20	30	14.5	12.5	34	21	20	6	36
LG	133.5	108	65										

MAINTENANCE

1. Cover Removal: Pull forward evenly with both hands until the clip section is released.
2. Tube Removal: Carefully move the Tube upwards until the top Insert is fully engaged in the top End block.
3. Carefully move the bottom Insert down until it is fully engaged in the bottom End block.
4. Carefully move the Tube downwards and gradually pull the bottom forwards until released from the top Insert.
5. Insert Removal: Withdraw the Inserts by pulling towards each other, until clear of the End blocks.
6. O-Ring Replacement: This should be carried out carefully ensuring that no surfaces are damaged. Lubricating the O-Rings using a small amount of suitable grease is advisable.
7. Insert Replacement: Reverse stage 5, ensuring both fully engaged in End blocks.
8. Tube Replacement: Locate the top of the Tube onto the top Insert and carefully move the Tube upwards and gradually push the bottom backwards until fully engaged on the top Insert. Holding the Tube squarely on the top Insert, move the bottom Insert up until the O-Ring just meets the bottom of the Tube. Holding the bottom Insert firmly in place, move the top Insert (& tube) downwards until the Tube is fully engaged on the bottom Insert.
9. Cover Replacement: Reverse stage 1.

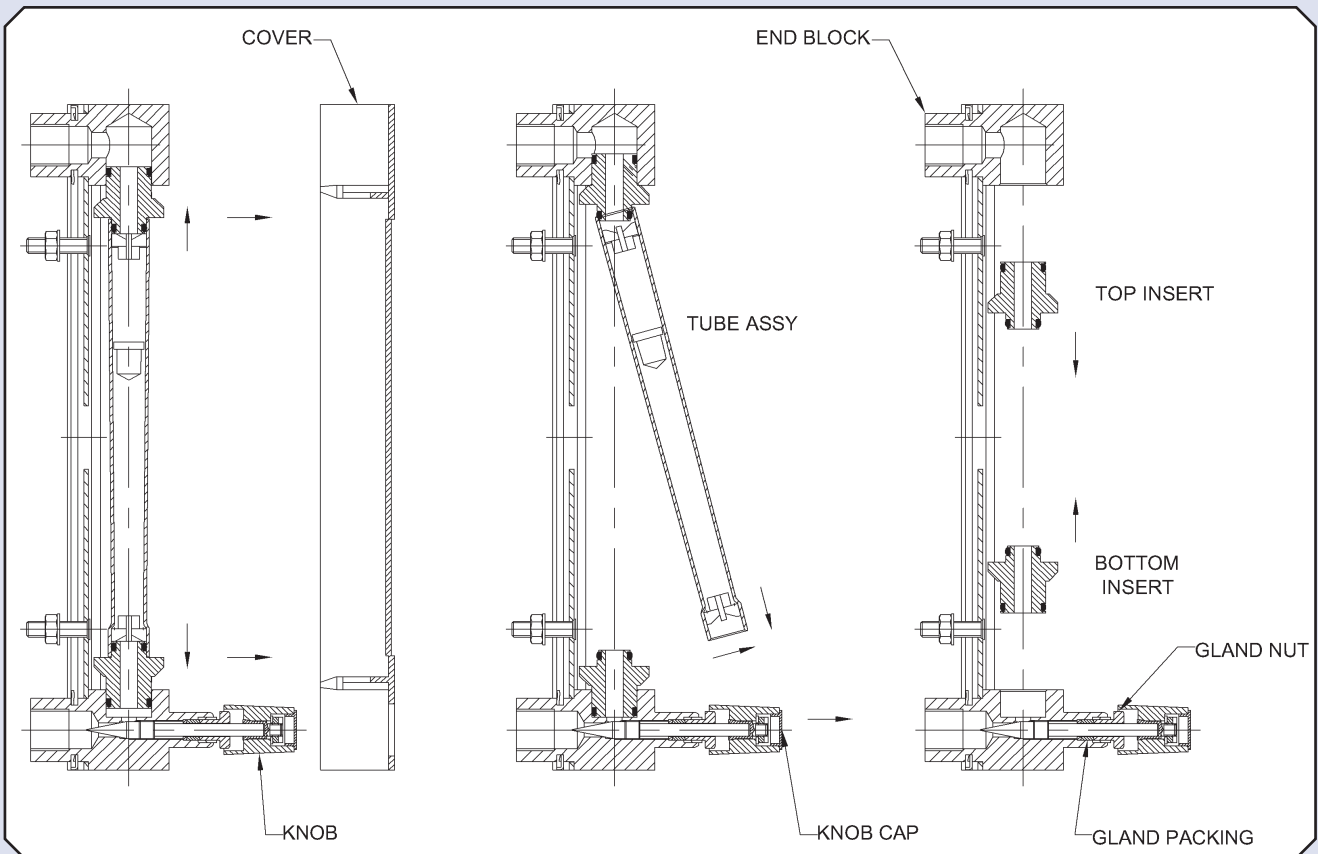

Every effort has been made during the preparation of this document to ensure the accuracy of statements and specifications. However, we do not accept liability for damage, injury, loss or expense caused by errors or omissions made. We reserve the right to withdraw or amend products or documentation without notice.



LICO Electronics GmbH
Klederinger Str. 31
A-2320 Kledering, Austria
office@lico.at www.lico.at
Tel. +43 1 706 43 00



www.mess-regeltechnik.at

www.platon-direct.eu

06HWAR0910