

DESCRIPTION

The Vision Turbine Meters comply with the lead-free provisions of the Safe Drinking Water Act. Available models include meters that are:

- Bisphenol A (BPA)-free
- BV1000 and BV2000 certified to NSF/ANSI/CAN 61 and 372

The meters are designed for flow measurement of low-viscosity, aggressive and non-aggressive liquids alike, including demineralized water, alkaline solutions, oils, salad oil, fuel/fuel consumption, beverages, water solutions and coolants.

- The BV1000 flow range is 0.026...0.65 gpm (0.1...2.5 lpm)
- The BV2000 flow range 0.13...9.2 gpm (0.5...35 lpm)
- The BV3000 flow range 1.32...17.17 gpm (5...65 lpm)

The meter is especially suitable for washing machines, dishwashers, coffee machines, laser cooling plants, solar solutions, bakery machines, steam cooking machines in large kitchen plants, and CD or DVD cleaning.

APPLICATIONS

- **Food Industry:** Coffee machines, vending machines, dispensing systems, bakery machines, and steamers
- **Medical Applications:** Sterilizers, slide staining, dental water jets, and dialysis machines
- **Chemical and Pharma Industry:** Dosing systems and bottling plants
- **Industrial applications:** Cooling systems, washing machines and plants, dosing systems, water treatment units, filter monitoring systems, and solar plants
- **Automotive:** Fuel consumption measurement and fuel injection systems

FEATURES

- Compact size
- Measurement in any meter orientation
- Operating pressure up to 362.50 psi (25 bar)
- Temperature range of -4...212° F (-20...100° C)
- Accuracy of $\pm 3\%$
- Resolution up to 83,000 ppg (22,000 ppl), depending on the model



MEASURING PRINCIPLE

The rotor is turned by the liquid force proportional to flow. A Hall effect sensor supplies pulses that can be used for digital or analog signal processing. The generated pulses are specified as a K-factor.

OPERATING PRINCIPLE

Liquid flow causes a bladed turbine inside the meter housing to turn at an angular velocity directly proportional to the velocity of the liquid measured. As the blades pass beneath a magnetic pickup coil, a frequency signal is generated.

Each pulse is equivalent to a discrete volume of liquid. The frequency pulse is directly proportional to the turbine angular velocity and the flow rate.

The large number of pulses provides high resolution. As the mass of the turbine is small, the response time is fast. It is not necessary to install a straight length of pipeline upstream of the meter.

The simple mechanical construction of the Vision meter provides a long lifespan without any loss of accuracy. Pressure spikes less than the burst pressure rating do not affect the measurements.

SPECIFICATIONS

Model	BV1000		BV2000						BV3000
	025*	050	075	100	150	250	350	650	
Flow Range	0.026... 0.65 gpm	0.13... 1.3 gpm	0.13... 2.0 gpm	0.26... 2.7 gpm	0.26... 4.0 gpm	0.26... 6.6 gpm	0.53... 9.2 gpm	1.32...17.17 gpm	
	0.1...2.5 lpm	0.5...5 lpm	0.5...7.5 lpm	1...10 lpm	1...15 lpm	1...25 lpm	2...35 lpm	5...65 lpm	
K-factor for Trogamid Housing	83,270 ppg	26100 ppg	17800 ppg	12500 ppg	8300 ppg	3785 ppg	2840 ppg	795 ppg	
	22,000 ppl*	6900 ppl	4700 ppl	3300 ppl	2200 ppl	1000 ppl	750 ppl	210 ppl	
DN mm	5 mm	6 mm	8 mm	6 mm	8 mm	8 mm	8 mm	12 mm	
Operating Pressure	362.5 psi (25 bar)								
Burst Pressure	1450 psi (100 bar)								
Inlet / Outlet Ports	1/4 in. NPT or G 1/4 in. (BSPP)	3/8 in. NPT or G 3/8 in. (BSPP)						3/4 in. NPT or G 3/4 in. (BSPP)	
Operating Temperature	- 4...212° F (- 20...100° C)								
Accuracy	± 3% of reading								
Repeatability	< 0.50 % under the same operating conditions								
Viscosity	up to 16 cSt								
Electrical Connection	Round cable LiYY 3 x 0.25 mm ² with free cable ends or *3-pin (2.8 x 0.5) mini DIN connector, EN 60529 * Mating connector is included.								
Filter	20...40 microns recommended								
Input Power	5...24V DC								
Power Consumption	~ 1.6 mA								
Output (Hz)	NPN sinking open collector								
Output Current	Max. 20 mA (Pull-up resistor required. See wiring diagram in User Manual.)								
Materials	Housing	Trogamid (NSF/ANSI/CAN 61 and 372 certified)						—	
	Turbine	Brass CuZn38Al-C (complies with lead-free provisions of the Safe Drinking Water Act)						—	
	Bearings	PPS Ferrite							
Weight	~0.35 oz (10 g)		~ 0.53 oz (15 g)						~ 1.23 oz (35 g)
	KTW-BWGL; NSF/ANSI/CAN 61 and 372 for BV1000 and BV2000								
Certifications	RoHS and CE compliant								

*The previous generation of Model 025 had a K-factor of 18,500 ppl.

Pressure Drop Chart

	Type		Part Number																
	gpm	lpm	025		050		075		100		150		250		350		650		
	—	—	psi	bar	psi	bar	psi	bar	psi	bar	psi	bar	psi	bar	psi	bar	psi	bar	
Pressure Drop Δp with Water Flow at 68° F (20° C)	0.13	0.5	0.29	0.02	—	—	—	—	—	—	—	—	—	—	—	—	—	—	
	0.26	1	0.73	0.05	<0	<0	<0	<0	<0	<0	<0	<0	<0	<0	<0	<0	—	—	
	0.40	1.5	2.18	0.15	—	—	—	—	—	—	—	—	—	—	—	—	—	—	
	0.53	2	3.63*	0.25*	<0	<0	0.87	0.06	<0	<0	0.73	0.05	<0	<0	<0	<0	—	—	
	1.32	5	—	—	1.74	0.12	2.90	0.20	0.73	0.05	2.90	0.20	0.73	0.05	0.73	0.05	0.00	0.00	
	2.64	10	—	—	5.80	0.40	10.15	0.70	2.90	0.20	5.80	0.40	2.47	0.17	2.18	0.15	0.14	0.01	
	3.96	15	—	—	13.05	0.90	—	—	5.80	0.40	—	—	3.92	0.27	3.63	0.25	0.29	0.02	
	5.28	20	—	—	18.85	1.30	—	—	10.15	0.70	—	—	6.96	0.48	6.53	0.45	0.72	0.05	
	6.60	25	—	—	—	—	—	—	—	—	—	—	9.43	0.65	8.70	0.60	1.02	0.07	
	7.93	30	—	—	—	—	—	—	—	—	—	—	—	—	13.34	0.92	1.59	0.11	
		35	—	—	—	—	—	—	—	—	—	—	—	—	—	—	—	2.03	0.14
		40	—	—	—	—	—	—	—	—	—	—	—	—	—	—	—	2.61	0.18
		45	—	—	—	—	—	—	—	—	—	—	—	—	—	—	—	3.34	0.23
		50	—	—	—	—	—	—	—	—	—	—	—	—	—	—	—	4.06	0.28
		55	—	—	—	—	—	—	—	—	—	—	—	—	—	—	—	4.93	0.34
	60	—	—	—	—	—	—	—	—	—	—	—	—	—	—	—	5.80	0.40	
	65	—	—	—	—	—	—	—	—	—	—	—	—	—	—	—	6.82	0.47	

*Value applies to 0.66 gpm (2.50 lpm)

PHYSICAL DIMENSIONS

BV1000 (G 1/4 in. or 1/4 in. NPT)

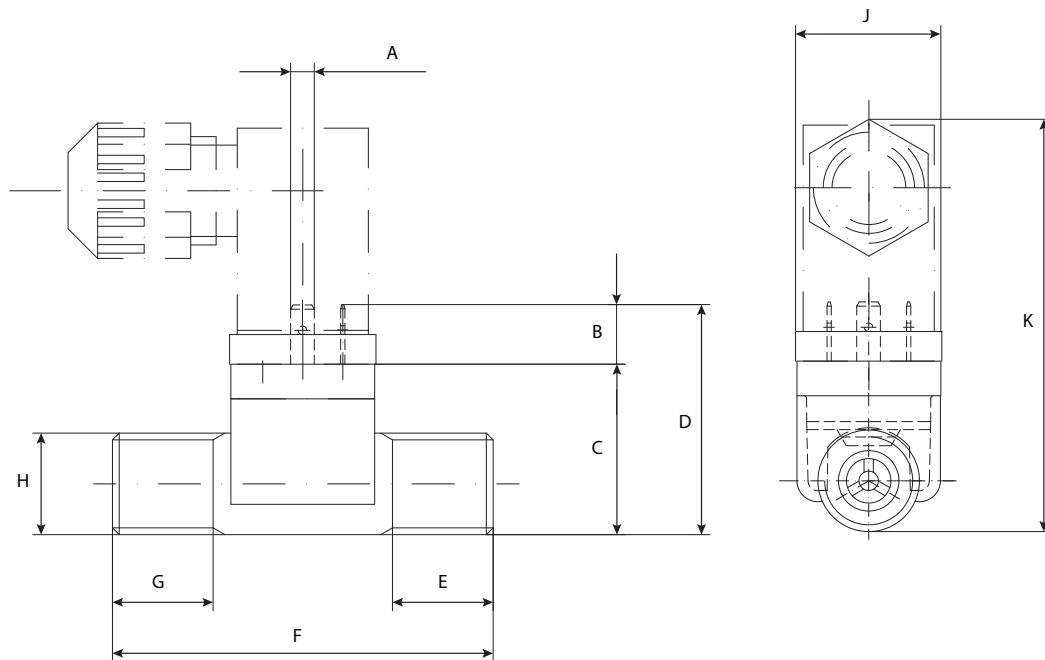

A in. (mm)	B in. (mm)	C in. (mm)	D in. (mm)	E in. (mm)	F in. (mm)	G in. (mm)	H in. (mm)	J in. (mm)	K in. (mm)
0.11 (2.8)	0.27 (7)	0.79 (20)	1.06 (27)	0.43 (11)	1.77 (45)	0.43 (11)	G 1/4 in. or 1/4 in. NPT	0.67 (17)	1.93 (49)

BV1000 (G 1/4 in. or 1/4 in. NPT with Round Cable LiYY 3 x 0.25mm² and Free Cable Ends)

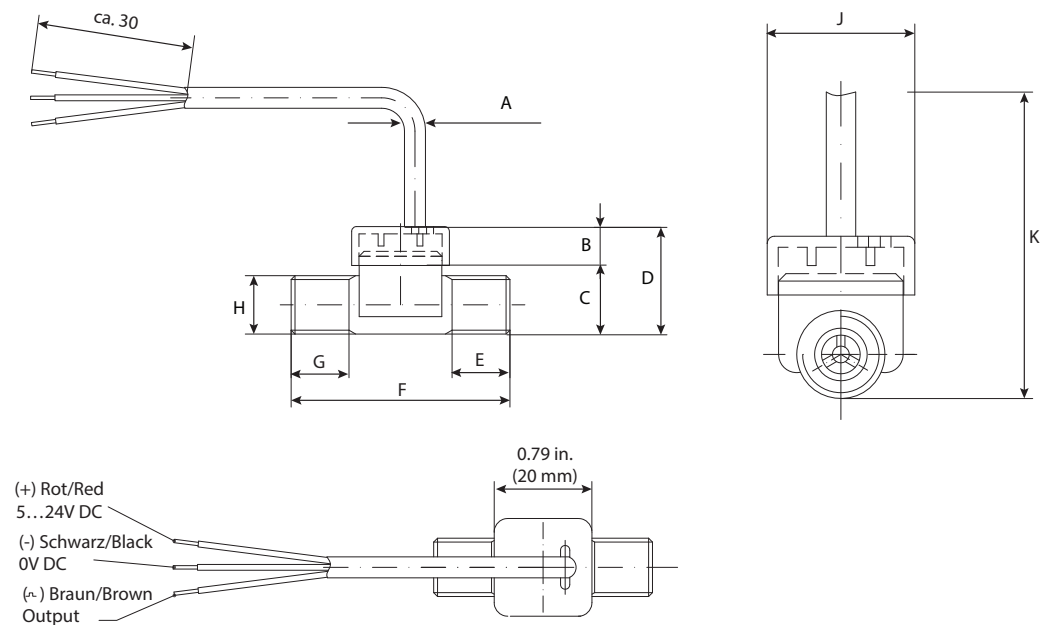

A in. (mm)	B in. (mm)	C in. (mm)	D in. (mm)	E in. (mm)	F in. (mm)	G in. (mm)	H in. (mm)	J in. (mm)	K in. (mm)
0.11 (2.8)	0.27 (7)	0.79 (20)	1.06 (27)	0.43 (11)	1.77 (45)	0.43 (11)	G 1/4 in. or 1/4 in. NPT	0.67 (17)	1.93 (49)

BV1000 (with DIN Connector)

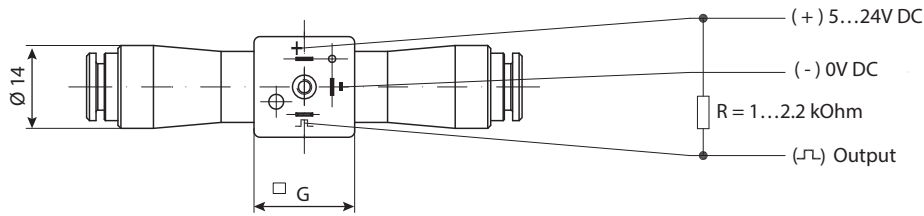
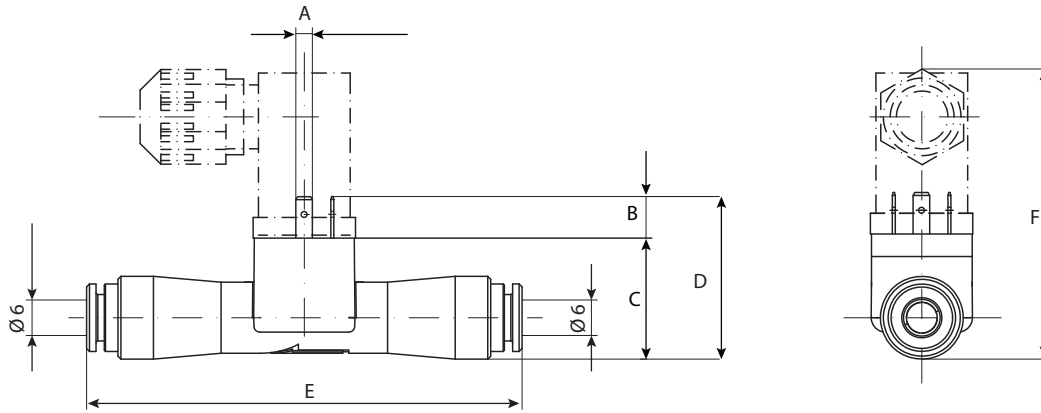

A	B	C	D	E	F	G
in. (mm)	in. (mm)	in. (mm)	in. (mm)	in. (mm)	in. (mm)	in. (mm)
0.11 (2.8)	0.27 (7)	0.79 (20)	1.06 (27)	2.90 (74)	1.93 (49)	0.67 (17)

BV1000 (with Cable)

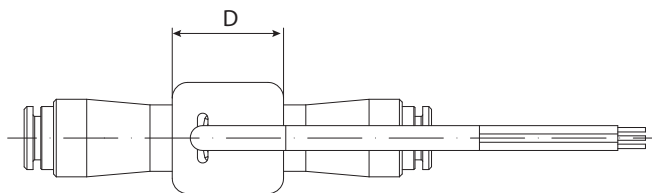
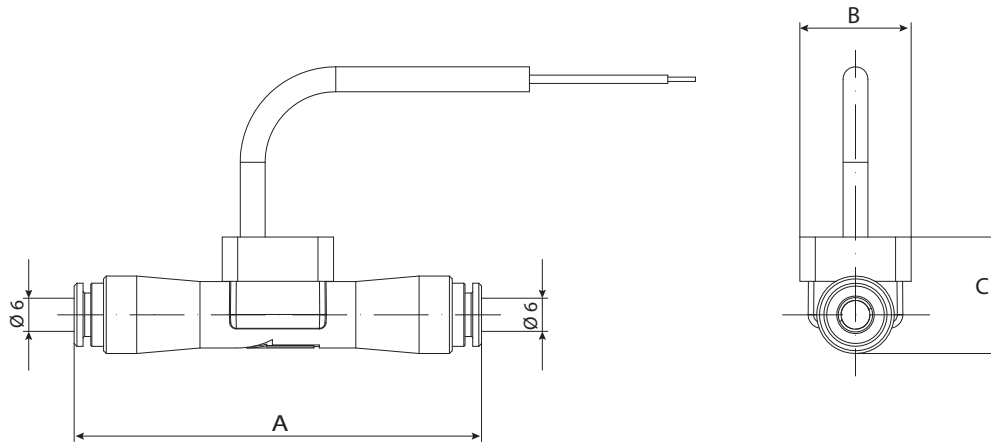

A	B	C	D
in. (mm)	in. (mm)	in. (mm)	in. (mm)
2.9 (73.6)	0.79 (20)	0.87 (22)	0.79 (20)

BV2000 (G 3/8 in. or 3/8 in. NPT)

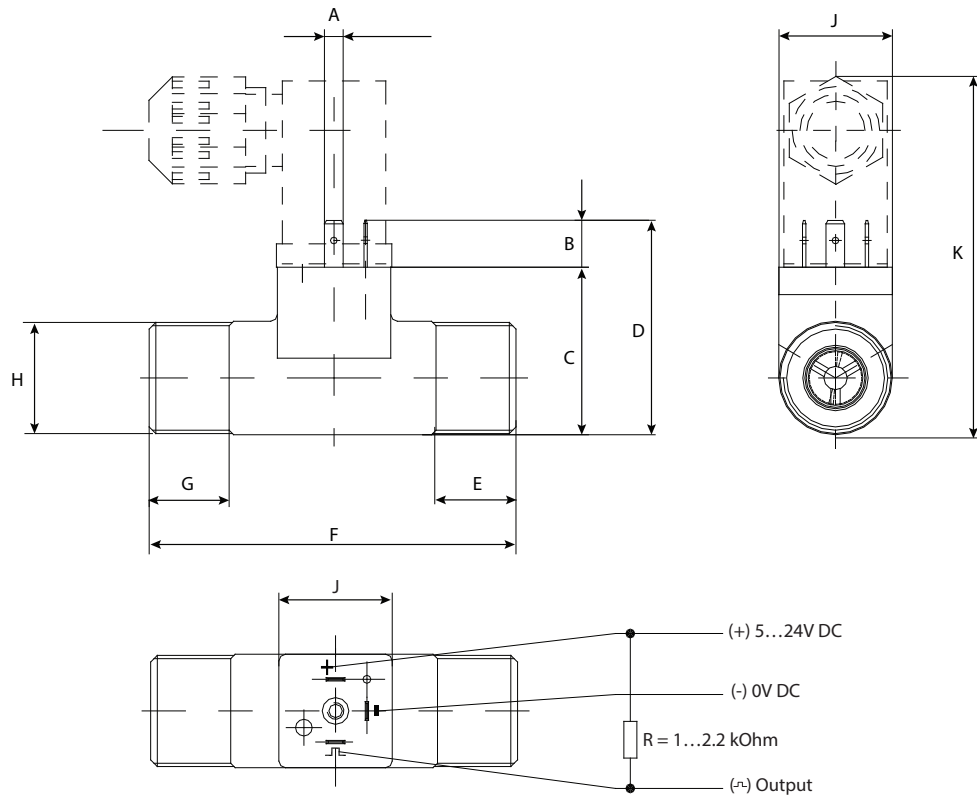

A	B	C	D	E	F	G	H	J	K
in. (mm)	in. (mm)	in. (mm)	in. (mm)	in. (mm)	in. (mm)	in. (mm)	in. (mm)	in. (mm)	in. (mm)
0.11 (2.8)	0.27 (7)	0.98 (25)	1.26 (32)	0.67 (17)	2.17 (55)	0.67 (17)	G 3/8 in. or 3/8 in. NPT	0.67 (17)	2.13 (54)

BV2000 (G 3/8 in. or 3/8 in. NPT with Round Cable LiYY 3 x 0.25 mm² and Free Cable Ends)

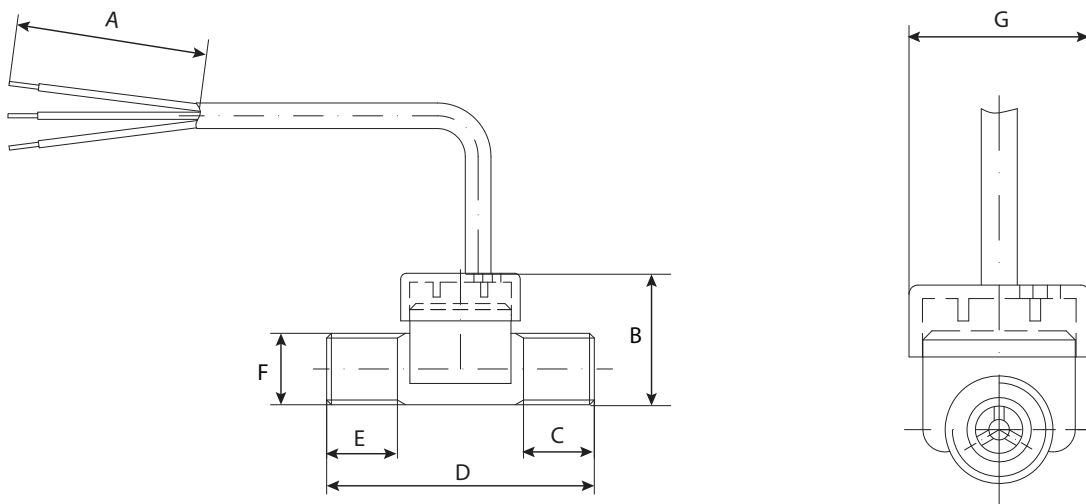

A	B	C	D	E	F	G
in. (mm)	in. (mm)	in. (mm)	in. (mm)	in. (mm)	in. (mm)	in. (mm)
1.18 (30)	1.06 (27)	0.47 (12)	2.17 (55)	0.47 (12)	G 3/8 in. or 3/8 in. NPT	0.79 (20)

BV3000 (G 3/4 in. or 3/4 in. NPT)

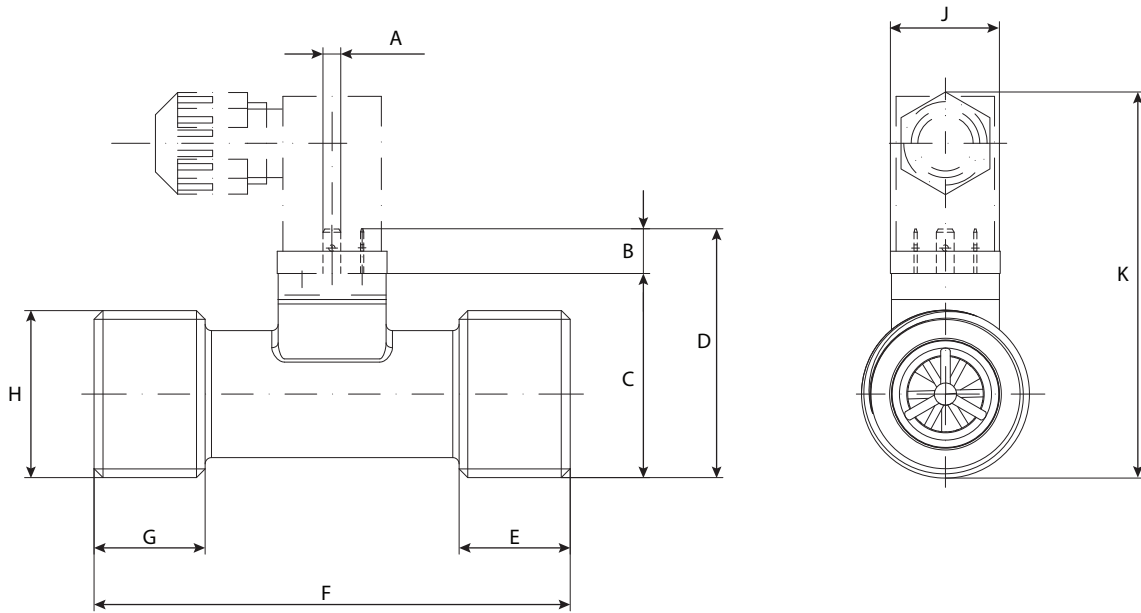

A in. (mm)	B in. (mm)	C in. (mm)	D in. (mm)	E in. (mm)	F in. (mm)	G in. (mm)	H in. (mm)	J in. (mm)	K in. (mm)
0.11 (2.8)	0.27 (7)	1.3 (33)	1.57 (40)	0.67 (17)	2.95 (75)	0.67 (17)	G 3/4 in. or 3/4 in. NPT	0.67 (17)	2.44 (62)

BV3000 (G 3/4 in. or 3/4 in. NPT with Round Cable LiYY 3 x 0.25 mm² and Free Cable Ends)

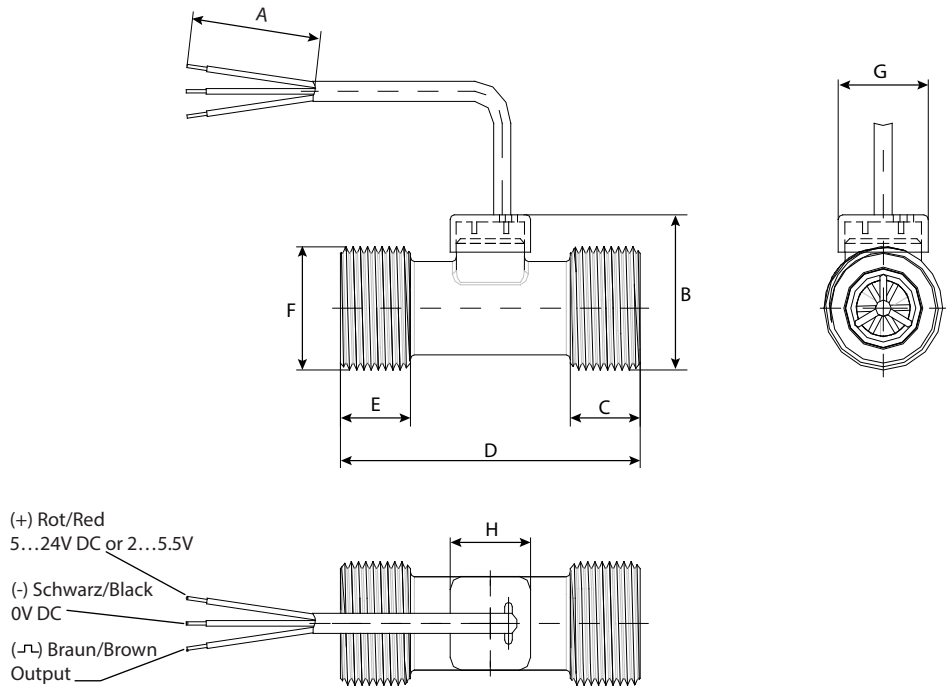

A in. (mm)	B in. (mm)	C in. (mm)	D in. (mm)	E in. (mm)	F in. (mm)	G in. (mm)	H in. (mm)
1.18 (30)	1.34 (34)	0.67 (17)	2.95 (75)	0.67 (17)	G 3/4 in. or 3/4 in. NPT	0.79 (20)	G 3/4 in. or 3/4 in. NPT

PART NUMBERING CONSTRUCTION

Vision Meter BV1000

	BV1000	-	TR	N	-	025	-	A
MODEL	BV1000							
MATERIAL	Trogamid Grilamid, reinforced fiberglass		TR	GF				
END CONNECTION	1/4" NPT 1/4" G Push-fit connection for OD = 6 mm			N G P				
FLOW RANGE	0.026 ... 0.65 gpm (0.1 ... 2.5 lpm) 0.026 ... 0.65 gpm (0.1 ... 2.5 lpm) and k-factor 85,163 ppg (22,500 ppl)					025 * 025		
ELECTRICAL CONNECTION	3 Pin (2.8 x 0.5) Mini DIN Connector, EN 60529 Cable (LiYY 3 x 0.25 mm ²) w/ Free Ends, 1 meter long							A B

* The previous generation of Model 025 had a K-factor of 18,500 ppl.

Vision Meter BV2000

	BV2000	-	TR	N	-	050	-	A
MODEL	BV2000							
MATERIAL	Trogamid		TR					
END CONNECTION	3/8" NPT 3/8" G			N G				
FLOW RANGE	0.13 ... 1.3 gpm (0.5 ... 5 lpm) 0.13 ... 2.0 gpm (0.5 ... 7.5 lpm) 0.26 ... 2.7 gpm (1 ... 10 lpm) 0.26 ... 4.0 gpm (1 ... 15 lpm) 0.26 ... 6.6 gpm (1 ... 25 lpm) 0.53 ... 9.2 gpm (2 ... 35 lpm)					050 075 100 150 250 350		
ELECTRICAL CONNECTION	3 Pin (2.8 x 0.5) Mini DIN Connector, EN 60529 Cable (LiYY 3 x 0.25 mm ²) w/ Free Ends, 1 meter long							A B

Vision Meter BV2000 Brass

BV2000 - BR N - 080 - A

MODEL

BV2000

BV2000

MATERIAL

Brass

BR

END CONNECTION

3/8" NPT

N

3/8" G

G

FLOW RANGE

0.5 ... 2.11 gpm (2 ... 8 lpm) and k-factor 15906 ppg (4200 ppl)

080

0.8 ... 6.6 gpm (3 ... 25 lpm) and K-factor 3484 ppg (920 ppl)

250

ELECTRICAL CONNECTION

3 Pin (2.8 x 0.5) Mini DIN Connector, EN 60529

A

Cable (LiYY 3 x 0.25 mm²) w/ Free Ends, 1 meter long

B

Vision Meter BV3000

BV3000 - TR N - 650 - A

MODEL

BV3000

BV3000

MATERIAL

Trogamid

TR

END CONNECTION

3/4" NPT

N

3/4" G

G

FLOW RANGE

1.32 ... 17.17 gpm (5 ... 65 lpm)

650

ELECTRICAL CONNECTION

3 Pin (2.8 x 0.5) Mini DIN Connector, EN 60529

A

Cable (LiYY 3 x 0.25 mm²) w/ Free Ends, 1 meter long

B



LICO Electronics GmbH
 Iederinger Strasse 31
 A-2320 Kledering, Austria
 E-mail: sales@lico.at | office@lico.at
 Tel.: +43 1 706 4300

LICO Mechatronic Kft.
 Raba u. 4.
 H-2030 Erd, Hungary
 Email: sales@lico.hu / sales@lico.at
 Tel: +36 23 520 138

www.platon-direct.eu