

## OPERATION & MAINTENANCE MANUAL

### LPCB APPROVED GAPMETER TYPE SGUV MK.2

OMM1002

---

*Every effort has been made during the preparation of this document to ensure the accuracy of statements and specifications. However, we do not accept liability for damage, injury, loss or expense caused by errors or omissions made. We reserve the right to withdraw or amend products or documentation without notice.*



**LICO Electronics GmbH**  
lederinger Strasse 31  
A-2320 Kledering, Austria  
E-mail: [sales@lico.at](mailto:sales@lico.at) | [office@lico.at](mailto:office@lico.at)  
Tel.: +43 1 706 4300

**LICO Mechatronic Kft.**  
Raba u. 4.  
H-2030 Erd, Hungary  
Email: [sales@lico.hu](mailto:sales@lico.hu) / [sales@lico.at](mailto:sales@lico.at)  
Tel: +36 23 520 138

[www.platon-direct.eu](http://www.platon-direct.eu)

## Contents

<b>Introduction</b> .....	1
<b>Principles of Operation</b> .....	1
<b>Materials of Construction</b> .....	1
<b>Specification</b> .....	2
<b>Installation</b> .....	3
Prior to Installation.....	3
Carrier Installation.....	3
Indicator Installation.....	3
<b>Recommended Pipeline Configuration</b> .....	4
<b>Instrument Configuration—Horizontal Pipelines</b> .....	5
<b>Instrument Configuration—Vertical Pipelines</b> .....	6
<b>Operation</b> .....	7
<b>Maintenance</b> .....	8
Glass Tube Cleaning or O-Ring/Glass Tube Replacement.....	8
Filter Cleaning or O-Ring/Filter Element Replacement.....	8
By-pass Loop Air Removal .....	8
<b>Spares</b> .....	9-10
<b>Returns &amp; Warranty</b> .....	11



**LICO Electronics GmbH**  
 lederinger Strasse 31  
 A-2320 Kledering, Austria  
 E-mail: sales@lico.at | office@lico.at  
 Tel.: +43 1 706 4300

**LICO Mechatronic Kft.**  
 Raba u. 4.  
 H-2030 Erd, Hungary  
 Email: sales@lico.hu / sales@lico.at  
 Tel: +36 23 520 138

[www.platon-direct.eu](http://www.platon-direct.eu)

## Introduction

The SGUV Mk.2 is a flow meter specifically designed to meet the requirement for a direct reading flow meter for use in Automatic Sprinkler, Water spray or Deluge systems. It is approved for regular monitoring and testing of such systems by the LPCB (Loss Prevention Certification Board), under their 'Rules for Automatic Sprinkler Installations' (LPS1045), in the UK.

The SGUV Mk.2 provides a robust, direct reading flow meter for 50, 80, 100, 150 & 200 mm pipelines and is suitable for use in both Horizontal & Vertical pipes, with the flow in any direction:

- Horizontally: Left to Right  
Right to Left
- Vertically: Upwards  
Downwards

Full bore Isolation valves are located in the by-pass loop, allowing meter isolation for Filter cleaning & Tube replacement. The inline Filter avoids clogging of the by-pass loop with any pipeline debris. In addition, a Rodding device ensures that the secondary Restrictor Orifice remains clear of any smaller particles or algae. Bleed/Drain valves allow venting of trapped Air or draining of the isolated Indicator by-pass loop.

## Principles of Operation

The SGUV Mk.2 is a combination of two simple measuring elements:

1. Installed in the main pipeline is a sharp edged Orifice, mounted in a Carrier ring. This assembly produces a pressure drop proportional to the square root of the flow.
2. Installed across the main Orifice/Carrier assembly is an Indicator by-pass loop containing an accurately calibrated Restrictor (secondary Orifice). This Restrictor converts the main Orifice pressure drop into flow rate, which is directly proportional to the main pipeline flow.

## Materials of Construction

<b>Carrier Assy</b>	Orifice plate: Stainless Steel mounted in: carrier, steel, red polyester powder coated in two styles
<b>Indicator Assy</b>	Housing: die-cast aluminum alloy, white polyester powder coated. Bezel: die-cast aluminum alloy, black polyester powder coated. Window: Perspex  Isolation valves; full bore brass ball valve, bright nickel plated. Rodding device: Stainless Steel. Filter element: Stainless Steel with 1.5mm perforations. Filter housing: TPX.  Other pipes and connectors: copper and brass, bright nickel plated. Seals: nitrile and polyurethane. Bleed/drain valve seats: PTFE
<b>Tube Assy</b>	Tube: Borosilicate glass with 100 mm fused in ceramic scale. Float: Stainless Steel Float stops: Polypropylene



## Specification

<b>Sizes</b>	50, 80, 100, 150 & 200 mm nominal bores
<b>Ranges</b>	See Table 1
<b>Mounting</b>	Either flange or grooved styles available Flanged to suit BS10 Table "E" (also suitable for Table 'D') flanges Grooved to suit Victaulic® grooved piping system Other manufacturers products can be used providing they conform to the Victaulic® Specification
<b>Accuracy</b>	±5 % at various test flows specified by LPCB (see Table 1)
<b>Temperature</b>	Design, -30 to 80°C Operation, 15°C
<b>Pressure</b>	Design, 30 bar g maximum @ 15°C, hydraulic Operation, 12 bar g maximum @ 20°C
<b>Pressure Drop</b>	65% of the orifice pressure loss (354" wg) is recovered at maximum flow
<b>Approval</b>	By LPCB to LPS1045 standard LPCB Reference No's 088a/05-14 (see Table 2 for Platon Ref's)
<b>LPCB Listing</b>	Approved Fire & Security Products & Services Part 5—Automatic Sprinkler, Water Spray & Deluge Systems Section 6—Direct Reading Flow Meters



**Table 1—Flow Ranges**

LPCB Ref NO.	Nominal Pipe Size (mm)	Flow Range dm <sup>3</sup> /min	Test Flow dm <sup>3</sup> /min	Accuracy @ Test Flows dm <sup>3</sup> /min
088a/05, 088a/10	50	150-750	500	±25
088a/06, 088a/11	80	300-2300	800	±40
			1300	±65
088a/07, 088a/12	100	500-3500	1500	±75
			2200	±110
088a/08, 088a/13	150	900-8200	2500	±125
			3500	±175
			4500	±225
088a/09, 088a/14	200	2500-12500	5000	±250
			7000	±350
			9000	±450

**Table 1—Flow Ranges**

Flanged Carrier Ref's		Groove Carrier Ref's	
LPCB*	Platon~	LPCB*	Platon~
088a/05	F1/5	088a/10	F1/10
088a/06	F1/6	088a/11	F1/11
088a/07	F1/7	088a/12	F1/12
088a/08	F1/7	088a/13	F1/13
088a/09	F1/9	088a/14	F1/14

\* The LPCB ref No. appears on the Carrier only

~ The Platon ref No. appears on both the Carrier and Tube

Also, the Tube & Float assemblies of a particular NB are universal between the 2 carrier styles and therefore, carry both Platon Ref No's, i.e. F1/6 or F1/11



### LICO Electronics GmbH

Iederinger Strasse 31  
A-2320 Kledering, Austria  
E-mail: sales@lico.at | office@lico.at  
Tel.: +43 1 706 4300

### LICO Mechatronic Kft.

Raba u. 4.  
H-2030 Erd, Hungary  
Email: sales@lico.hu / sales@lico.at  
Tel: +36 23 520 138

## Installation

1. Check the instrument for any transit damage. Any damage to the by-pass loop could increase resistance to flow and therefore render calibration inaccurate.
2. Re-check that the instrument is suitable for the chosen application.
3. Check that the box includes (for complete instruments only):
  - a) A Carrier of either Flanged or Grooved style.
  - b) An Indicator by-pass loop, assembled for Horizontal pipelines & Left to Right flows.
  - c) 2 x Tube & Float Assemblies (1x assembled in Indicator housing).
  - d) An impulse pipe for Vertically, Upwards flows.
  - e) An impulse pipe for Vertically, Downwards flows.
4. Check that the Platon Reference numbers on the Carrier and glass Tube are identical.  
i.e. F1/\*\* (see Table 2).
5. Remove any packing materials, as necessary, from any component.
6. For best accuracy ensure that the pipeline bores are smooth and that they match that of the Carrier.
7. Select a location to ensure compliance with the Recommended Pipeline Configurations (see Fig 1 & Table 3).

### Carrier Installation

#### Flanged Style

1. The Carrier should be mounted inside the bolt circle of two flanges (see Specification).
2. Ensure the Carrier is precisely centred in relation to the pipeline & flanges.
3. Ensure that the Gaskets (not supplies) either side of the Carrier has an Inside Diameter (I.D.) greater than or equal to the pipe nominal bore. Also ensure that when assembled no part of the gasket protrudes into the pipeline at any point.

#### Grooved Style

1. The Carrier should be mounted to the pipeline using two appropriately specified joints.
2. Always lubricate gasket joints, so as to avoid pinching and leakage.

### Both Carrier Styles

1. Ensure the Carrier flow label matches the flow direction of the pipeline.
2. Ensure the process connections of the Carrier protrude from the pipeline in the correct direction to ensure:
3. Vertical Indicator assembly.
4. Readable Viewing angle.

### Indicator Installation

1. Based on the pipeline orientation and direction of flow, assemble the Indicator by-pass loop, using the appropriate impulse pipe. Note the factory supplied set-up, is for Horizontal, Left to Right flows.
2. Whatever the main pipeline configuration ensure that the Float moves freely in the glass Tube and that the indicator is accurately Vertical.
3. Rotate the Indicator housing & glass tube, in relation to the rest of the Indicator by-pass loop, to obtain the best viewing angle.

**Table 3—Recommended Minimum Upstream & Downstream Pipe Lengths (See Fig. 1)**

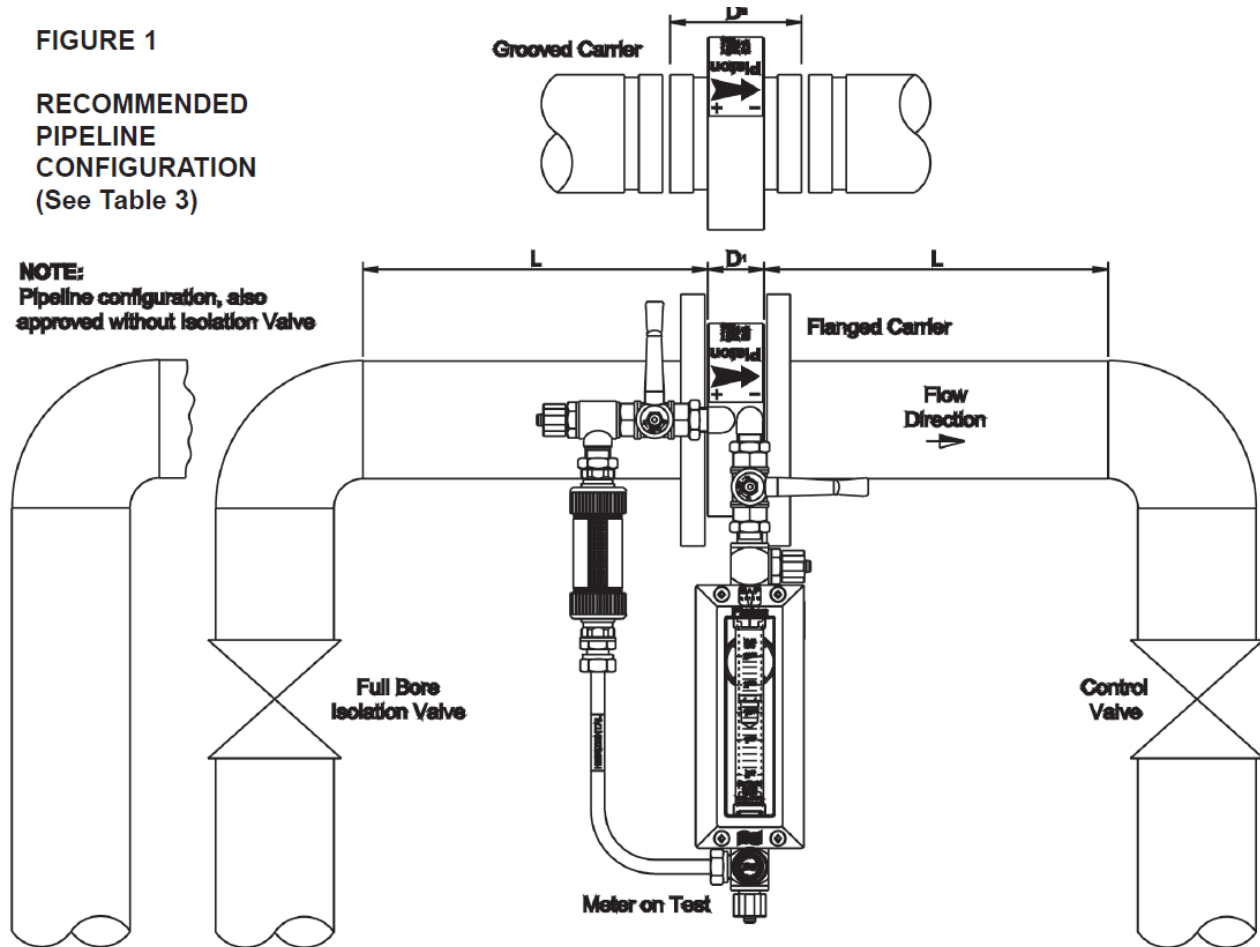
Carrier	Nominal Bore (mm) & Pipe Style Specification				
	50	80	100	150	200
	BS1387				BS3600
L	250	400	500	750	1000
D1 Flanged	38.1				
D2 Grooved	89.1			98.1	
	Min 5 x NB				

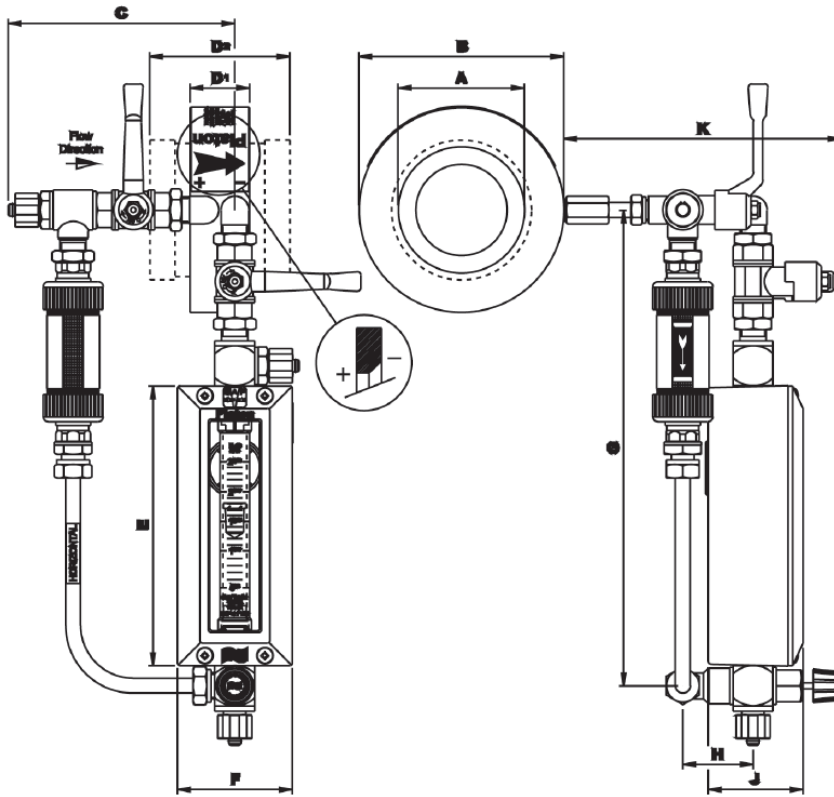


FIGURE 1

**RECOMMENDED  
PIPELINE  
CONFIGURATION**  
(See Table 3)

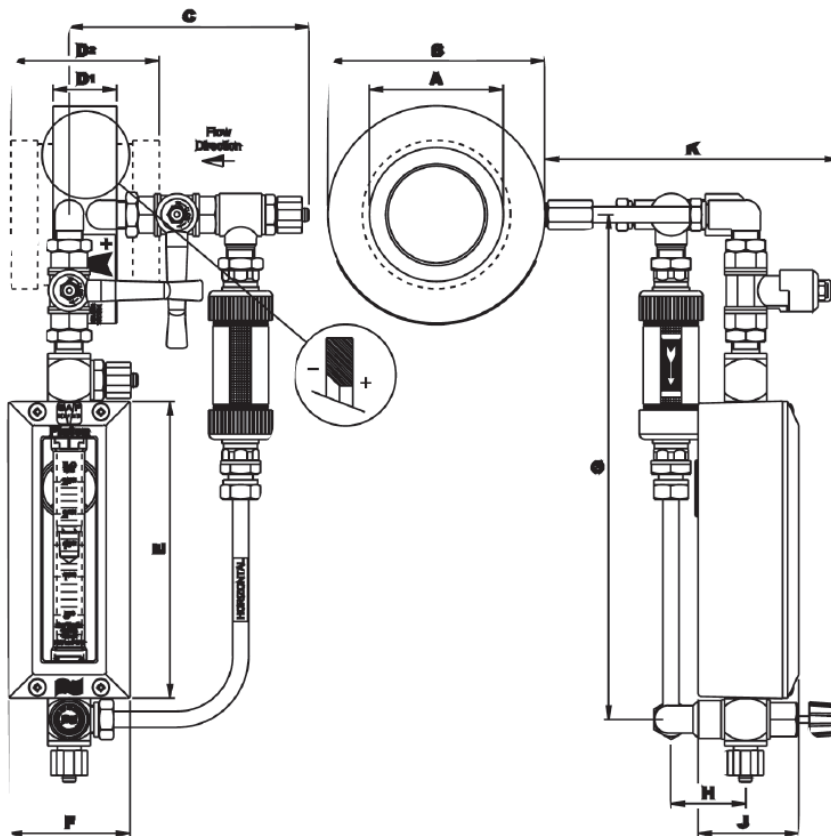
**NOTE:**  
Pipeline configuration, also  
approved without Isolation Valve





**FIGURE 2**  
**HORIZONTAL PIPELINE - FLOW LEFT TO RIGHT**

	mm
A	=NB
B	PCD - Bolt Dia
C	150 max
D1	See Table 3
D2	See Table 3
E	178
F	73
G	305 max
H	45
J	60
K	180 max



**FIGURE 3**  
**HORIZONTAL PIPELINE - FLOW RIGHT TO LEFT**



**LICO Electronics GmbH**  
 lederinger Strasse 31  
 A-2320 Kledering, Austria  
 E-mail: sales@lico.at | office@lico.at  
 Tel.: +43 1 706 4300

**LICO Mechatronic Kft.**  
 Raba u. 4.  
 H-2030 Erd, Hungary  
 Email: sales@lico.hu / sales@lico.at  
 Tel: +36 23 520 138

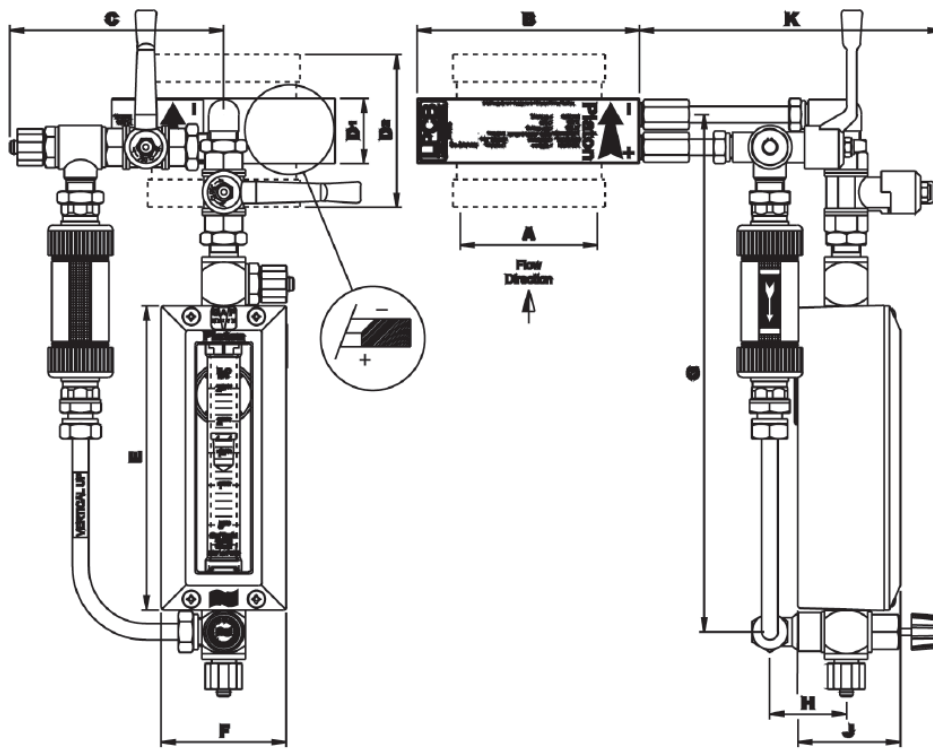


FIGURE 4

VERTICAL PIPELINE -  
FLOW UPWARDS

	mm
A	=NB
B	PCD - Bolt Dia
C	133 max
D1	See Table 3
D2	
E	178
F	73
G	305 max
H	45
J	60
K	180 max

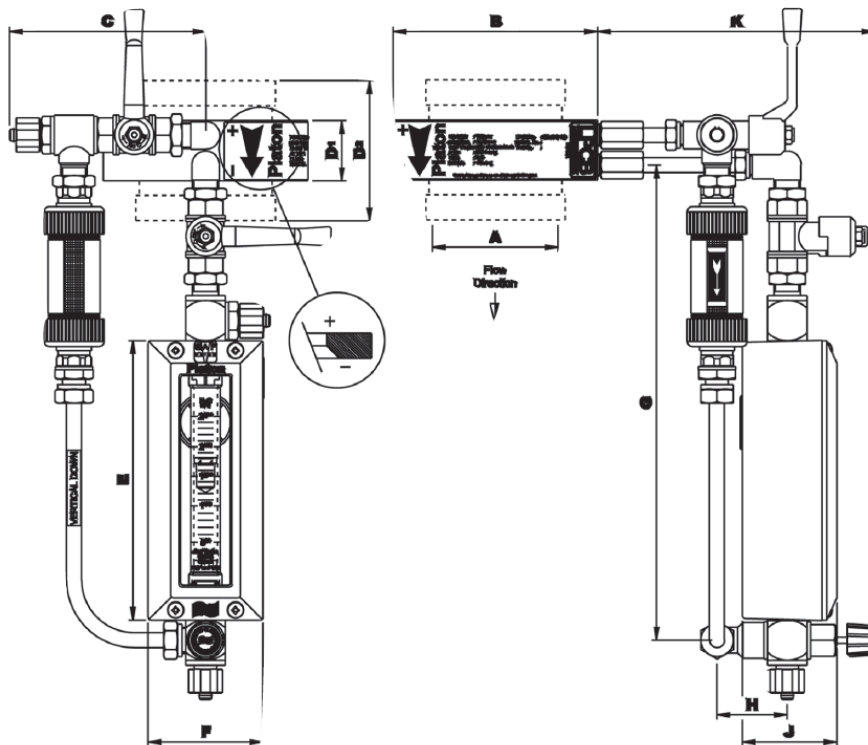


FIGURE 5

VERTICAL PIPELINE -  
FLOW DOWNWARDS



**LICO Electronics GmbH**  
 lederinger Strasse 31  
 A-2320 Kledering, Austria  
 E-mail: sales@lico.at | office@lico.at  
 Tel.: +43 1 706 4300

**LICO Mechatronic Kft.**  
 Raba u. 4.  
 H-2030 Erd, Hungary  
 Email: sales@lico.hu / sales@lico.at  
 Tel: +36 23 520 138

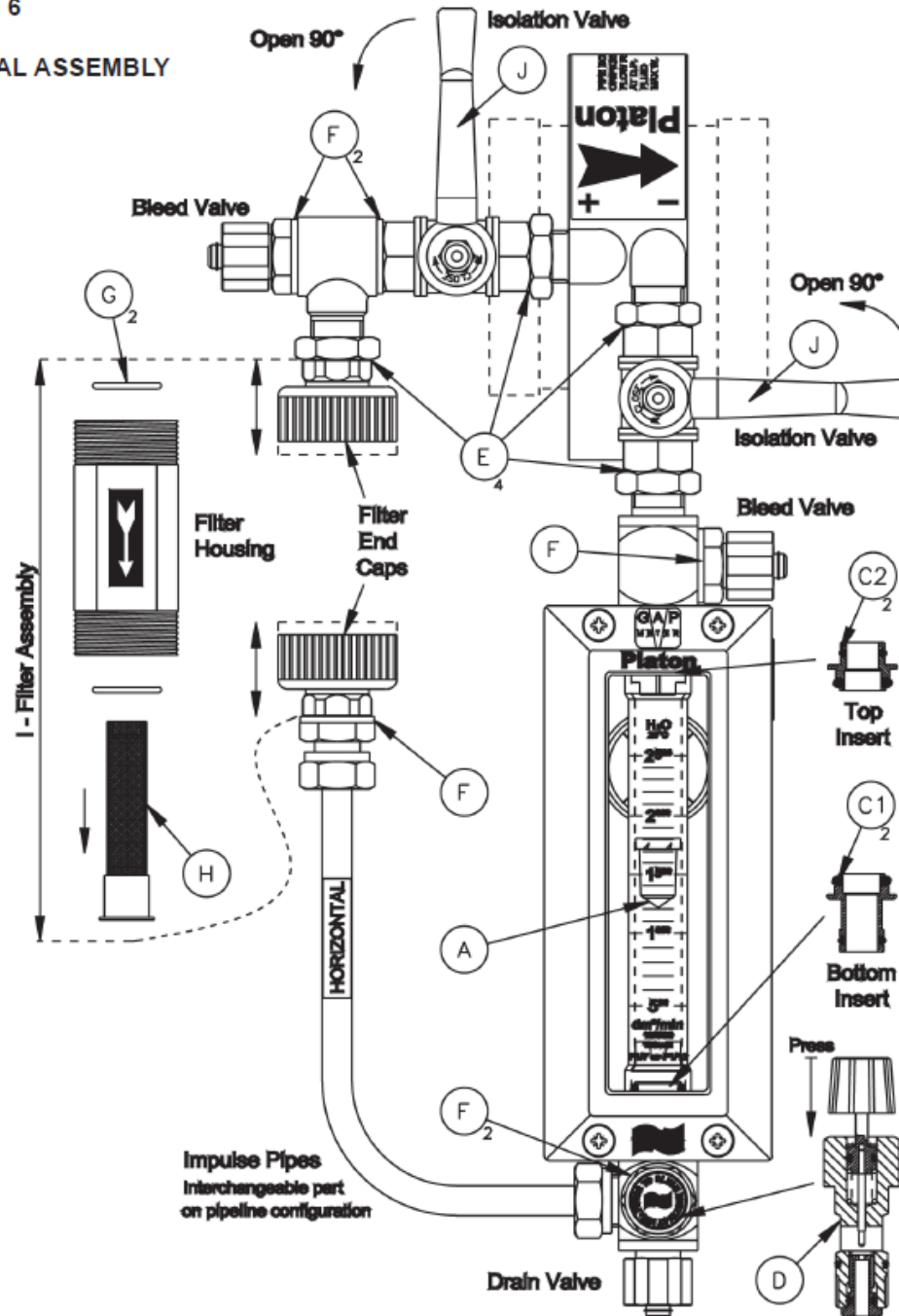


## Operation

1. Ensure that the Filter (H) is clean.
2. Check that no pipe debris is obstructing the Restrictor by pressing the Restrictor cleaning valve (D).
3. Bleed all air from the Indicator by-pass loop before taking any flow readings.
4. Make sure that the Isolating Valves (J) are fully open before taking any flow readings.
5. Read the top edge of the Float.
6. When not in use the Isolation Valves should be closed and the Indicator by-pass loop drained. Once the unit has been fully drained all the Bleed/Drain Valves should then be closed.

FIGURE 6

### GENERAL ASSEMBLY

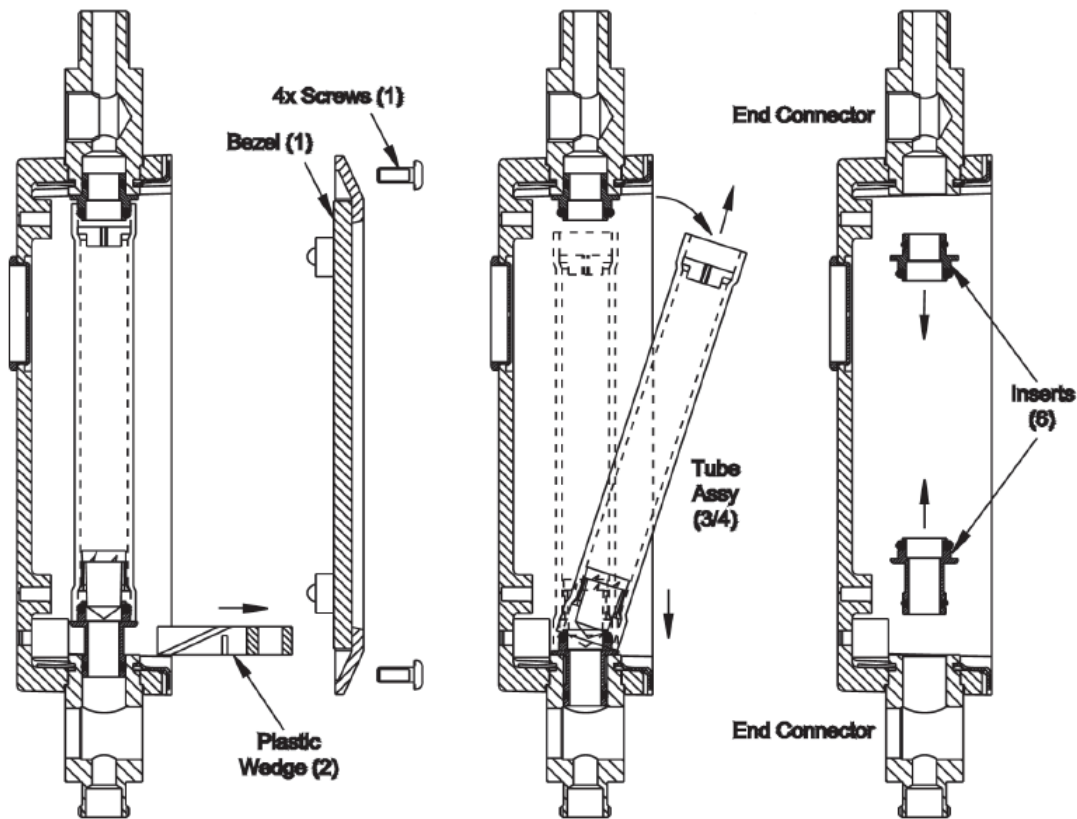


## Maintenance

### Glass Tube Cleaning or O-ring/Glass Tube Replacement (See Fig. 7)

1. Unscrew 4x screws and remove the bezel.
2. By pulling towards you, remove the plastic wedge, located at the bottom of the housing.
3. Slide the tube downwards, towards the gap created by the removal of the plastic wedge, until the bottom Insert is fully engaged in its end connector.
4. Ensure that the top insert & end connector remain engaged together. Noting the tube & float orientation, carefully tilt the top of the tube towards you, until it is clear of the Insert, then pull upwards.
5. If the O-rings DO NOT require replacing, then proceed to instruction 11.
6. Remove both Inserts from their end connectors by pulling, noting which Insert came from which end connector. To aid with their removal the plastic wedge can now be used as a sliding wedge.
7. Remove 2x old O-rings from each insert.
8. Care should be taken that the new O-rings (C1 & C2) are not damaged when assembling them to the inserts.
9. Moistening the O-rings with a suitable lubricant is advisable, such that when re-assembling to the end connectors or tube the O-rings are not damaged.
10. As previously noted, push the inserts back into the appropriate end connector, fully.
11. To replace the tube (A), reverse steps 1-4, using steps 12 & 13, for guidance.
12. To aid engagement and reduce possibility of O-ring damage, rotate the tube back & forth, whilst pushing the tube & insert together.
13. Once the tube (A) is located on the bottom Insert, use the plastic wedge on the bottom Insert as a sliding wedge to force the top Insert & tube together.

**FIGURE 7 - TUBE CLEANING & O-RING REPLACEMENT**



## Filter Cleaning or O-ring/Filter Element Replacement (See Fig 6)

1. Unscrew both end caps.
2. Remove Filter Housing from the Indicator by-pass loop, noting Flow direction label orientation.
3. Back wash Housing & Filter assembly using clean water.
4. As necessary change the O-rings (G) or Filter (H).
5. Reassemble in reverse order.

### By-pass Loop Air Removal (See Fig 6)

1. Close the Isolation Valve nearest to where the Air was observed.
2. Open the Bleed Valve nearest to where the Air was observed.
3. Close the Bleed Valve when the Air has been removed.
4. Open the Isolation Valve.

### Spares

The instruments should not require maintenance to replace parts if the instrument is used in accordance with these instructions. However spare parts are available to meet most needs as detailed below:

For Complete Instruments, see Table 4.

For Major Assemblies, see Table 5.

For Components & Sub-Assemblies, see Table 6.

Complete assembled Instruments consist of a:

- Carrier of Flanged or Grooved style includes: Carrier, Process pipes, Ferrules & Nuts.
- 2 x Tube & Float assembly of a flow range to suit the Nominal Bore of the Carrier includes: Tube, Float and top & bottom Float stops.
- Indicator By-pass loop includes: parts starting at Elbows that join to Carrier Process pipes, except Tube & Float assembly.



#### LICO Electronics GmbH

Iederinger Strasse 31  
A-2320 Kledering, Austria  
E-mail: sales@lico.at | office@lico.at  
Tel.: +43 1 706 4300

#### LICO Mechatronik Kft.

Raba u. 4.  
H-2030 Erd, Hungary  
Email: sales@lico.hu / sales@lico.at  
Tel: +36 23 520 138

**Table 4—Complete Instrument**

NB	Flanged		Grooved	
	Part No.	Weight (kg)	Part No.	Weight (kg)
50	LPCB-F1/5	4.25	LPCB-F1/10	4.65
80	LPCB-F1/6	5.10	LPCB-F1/11	5.50
100	LPCB-F1/7	6.45	LPCB-F1/12	7.40
150	LPCB-F1/8	8.50	LPCB-F1/13	9.75
200	LPCB-F1/9	11.00	LPCB-F1/14	13.60

**Table 5—Major Assemblies**

NB	Carrier		Tube & Float*		By-Pass
	Flanged	Grooved	Flanged	Grooved	
50	LPCBC312	LPCB314	LGTF-F1/5	LGTF-F1/10	LPCB1
80	LPCBC512	LPCB514	LGTF-F1/6	LGTF-F1/11	
100	LPCBC612	LPCB614	LGTF-F1/7	LGTF-F1/12	
150	LPCBC812	LPCB814	LGTF-F1/8	LGTF-F1/13	
200	LPCBC912	LPCB914	LGTF-F1/9	LGTF-F1/14	

\*The Tube & Float assemblies of a particular NB are universal between the 2 Carrier styles. Two sets of codes have been included for simplicity. However, all Tubes, for each NB & Carrier style, carry both Platon Ref No's. (See Table 2).

**Table 6—Component & Sub-assemblies (See Fig. 6)**

Item	Description	Qty/Assy	Part No.
A	Tube & Float Assy	1	See Table 5
C1	Insert O-Rings—Tube to Insert	2	K23012*
C2	Insert O-Rings—End Connector to insert	2	K23056*
D	Restrictor Cleaning valve Assy	1	54150
E	Polyurethane Seals	4	K28115*
F	Bonded Seals	6	K23014*
G	Filter O-Rings	2	K23170*
H	Filter Element	1	56272
I	Filter Assembly (Includes G&H + Housing, End Connectors & Caps)	1	54149
J	Isolation Valves	2	K49356

\*Sold in packs of 10's



## Returns & Warranty

Before returning any goods to RM&C, you must obtain a Returns form containing a unique returns (CA) authorisation number. Failure to do so will result in the goods being returned to you, without any inspection, etc. To obtain this form, contact the QA department of our Sheffield office and by return the form will be faxed to you.

On receipt of the Returns form, fill in any required fields and return it with the goods to the Sheffield office. It is advisable to keep a copy of this form (with authorisation no.) for reference purposes. If the goods have come into contact with any processes or environments that may be harmful to a user, then COSHH Regulations must also be observed. It is requested that a Material Safety Data Sheet (MSDS) is also supplied with returned goods, if this is likely to be the case. If not provided and the goods are suspected of being contaminated, they will be returned to you. On receipt of the appropriate documentation, the goods will be examined and assessed in accordance with the terms of any Warranty agreement.

### Repairs

Prior to any repair work being carried out, you will be informed of our findings and any charges that may be incurred.

### Replacement

Prior to the supply of any replacements, you will be informed of our findings and any charges that may be incurred.

No replacements will be sent prior to receiving the goods back from you, unless an Order number is supplied to cover the cost of the new unit/s. After inspection, etc of the returned goods, a Credit may be issued, based on our findings.

### Warranty (extract from Terms and Conditions)

The warranty period is normally 12 months from the date of shipment, except as agreed at the time of sale.

Any misuse of the goods will void any warranty.

For full Warranty and other Contract details, refer to our 'Terms & Conditions'.

OMM1002 Page 9 of 9



0043



FM 22358



**LICO Electronics GmbH**  
lederinger Strasse 31  
A-2320 Kledering, Austria  
E-mail: sales@lico.at | office@lico.at  
Tel.: +43 1 706 4300

**LICO Mechatronic Kft.**  
Raba u. 4.  
H-2030 Erd, Hungary  
Email: sales@lico.hu / sales@lico.at  
Tel: +36 23 520 138

Page 11

[www.platon-direct.eu](http://www.platon-direct.eu)