

Platon Flostat Type MN

INSTALLATION

The Flostat should be of the appropriate Model (see Fig 1) to suit the application. It can be mounted at any angle, in any similarly nominal bored pipeline, but must be positioned appropriately for the model type & orientated to match the flow direction. The connector must be 1/4" BSP Parallel male with a stud length no longer than 5/16" excluding the thickness of a bonded seal.

Models of configuration 'A' are to be used for all liquids and with gases that have a regulated or a reasonably constant supply pressure and should be mounted downstream of other equipment.

Models of configuration 'B' are to be used with gases of varying inlet pressure, but regulated or reasonably constant output pressure or where the gas is discharging to atmosphere and should be mounted upstream of other equipment.

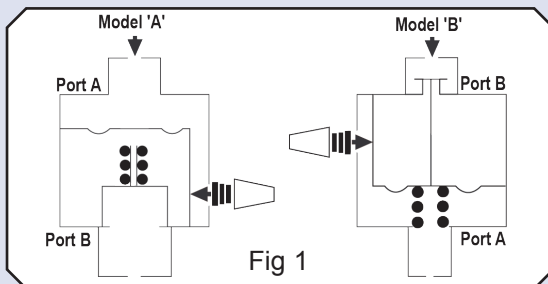

Threaded holes in the body either side of the control valve and also on the rear face allow the Flostat to be flush & panel mounted.

If mounted in close proximity to a flow meter then it must be ensured the installation is accurately vertical & that all joints are free of any leaks.

Although Flostat's with 'L' or 'M' control valves are fitted with 50 micron filters, it has a small surface area and is likely to clog up quickly, when used with unclean fluids. Due to this and the fact that 'H' control valve versions do not have filters fitted, it is advisable to ensure that the process supply is reasonably clean and also dry for gases.

When the Flostat is being used in liquid applications the Filter should be removed (where pre-installed), as it is likely that the flow can become restricted.

For dimensions & mounting options refer to certified drawing - C60

OPERATION (See Fig 2)

Rotating the control valve knob at any time varies the valve orifice size (A). As flow passes through this orifice a pressure difference ($P_1 - P_3$) is created across the diaphragm (C). As this pressure difference varies the diaphragm (B) modulates, maintaining the internal pressure drop ($P_1 - P_2$) constant and equal to the spring force. This in turn produces a constant flow rate, as determined by the control valve orifice size, at the Flostat's outlet.

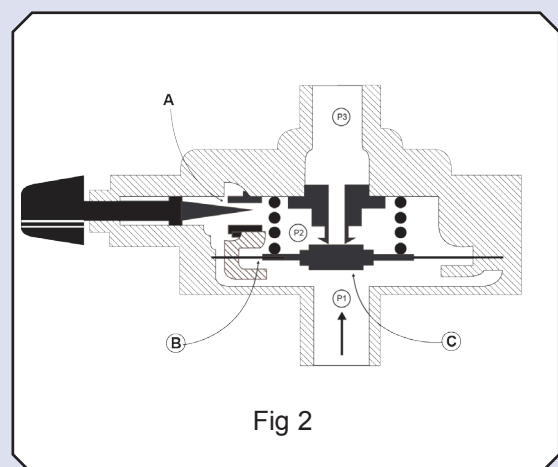

For accurate control it is necessary to ensure that the system pressure does not fall below the threshold value ($P_1 - P_3$), which is the minimum pressure required to provide the control force and to overcome friction losses.

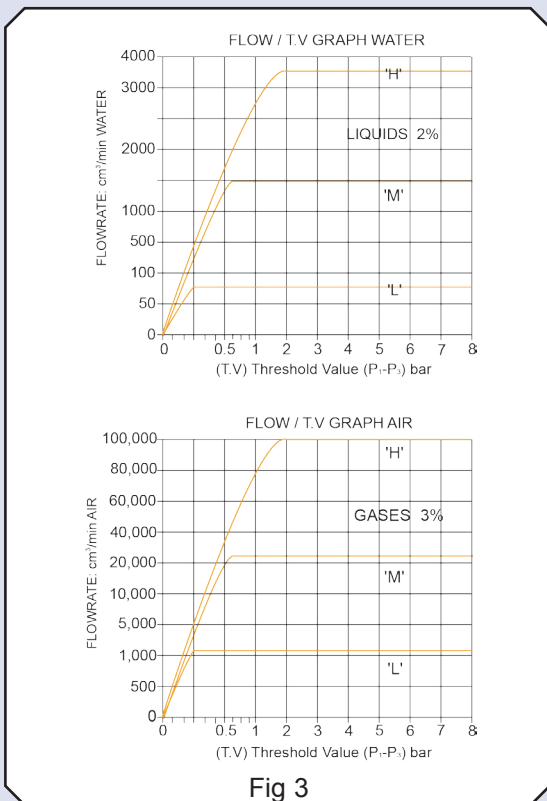

Valve	Flow Ranges (cm ³ /min)		Threshold Value (TV)@ max Flow $P_1 - P_3$ (bar g)
	Water@20°C	Air@ATP	
L	1-80	5-1,200	0.3
M	20-1,500	200-25,000	0.7
H*	200-3,600	4,000-100,000	2.3

* Model 'A' only

Special models MNT, MNG & MNX have been designed for different applications & therefore will have different performance characteristics, compared with the standard models detailed within this OMM.

It is advisable when first using the Flostat in Liquid applications, to purge any trapped air from the system, by completing the following:

- 1) Close an upstream isolation valve.
- 2) Set the Flostat control valve to fully open (anti-clockwise).
- 3) Apply a coarse vacuum to the downstream side.
- 4) Open the upstream isolation valve, slowly.

MAINTENANCE (See Fig 4)

The Flostat will not require attention if it is operated with clean fluids, but general wear & tear will occur.

The control valve gland packing (E) & O-ring seals (J & K) may be replaced, if leakage is still apparent after tightening of the gland nut & valve cartridge respectively.

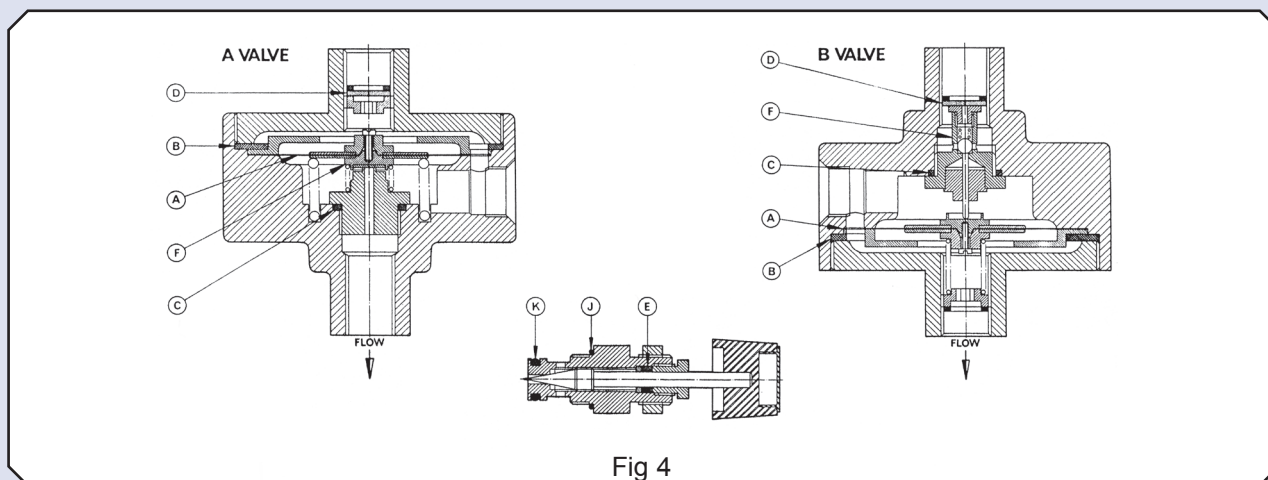

If the maximum controllable flow range appears to gradually reduce over time, this is probably due to gradual blockage of the inlet Filter.

- 1) Firstly remove the filter retaining washer & then the filter (D).
- 2) Replace filter.
- 3) Replace both components in reverse order.

Diaphragm Replacement (see Fig 2)

If the control valve fails to allow adjustment to the flow set point, this will probably be due to a ruptured diaphragm (A). Before dismantling the Flostat, first check that sufficient pressure drop is available across the Flostat, by measuring the pressures at both its inlet & outlet. Once it is confirmed that there is sufficient pressure drop (see flow range table, above) across the Flostat, only then dismantle the Flostat as follows:

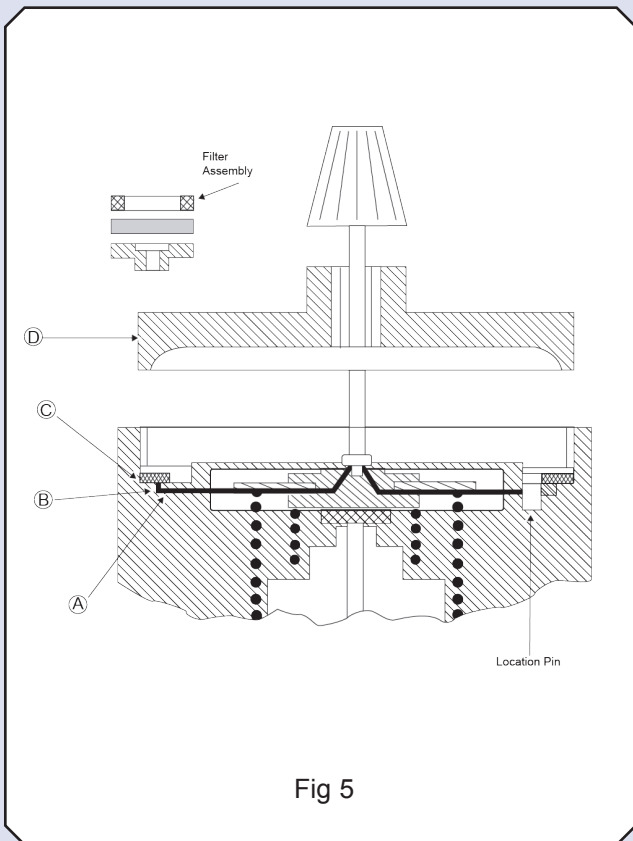

Fig 5

- 1) Unscrew the end Cover (D). For 'B' models refer to comment below.

- 2) Remove end cover gasket (C), clamp ring (B) & diaphragm assembly (A), noting the hole/slot positions in each component with respect to the body.
- 3) Assemble the new diaphragm assembly (screw head up) centrally into the body, locating the small hole near it's O.D. over the location pin, with the larger hole located over the control valve port hole. For 'A' models refer to comment below.
- 4) Reassemble the clamp ring on top of the diaphragm into a recess, maintaining the same hole positioning as that in 3).
- 5) Press the end cover gasket into position around the edge of the clamp ring, again maintaining the same hole positioning as that in 3) & 4).
- 6) For 'B' models replace the control spring onto the diaphragm boss.
- 7) Screw the end cover back in place, ensuring with 'B' models that the control spring locates into the centrally threaded through hole. Then tighten with a torque wrench:

Gasket Material	Nebar	PTFE
Cover Torque (Nm)	110	135

- 8) To ensure there are no leak paths pressure test the assembly to a minimum of 1.5x the working pressure.

Model 'A' Comment (see Fig.5)

When removing the end cover, clamp ring & diaphragm assembly on these models take care not to loose/dislodge the control Spring/s.

When reassembling, the control spring/s are uncompressed and therefore do not allow the diaphragm, etc... to be seated correctly. In order to achieve this the diaphragm assembly needs to be pressed & held down, whilst the remaining components are assembled.

Model 'B' Comment (see Fig.6)

When removing the end cover on these models take care not to loose the control spring.

Located in the connection thread of the end Cover is a spring Screw, which tensions the control Spring giving the appropriate instrument performance. This is factory set and if adjusted, will alter the Flostat operational behaviour.

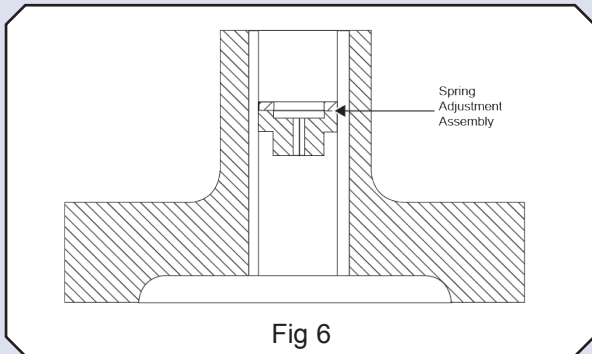

Fig 6

Service Component Spares Kits

Detailed below are the service kits containing the recommended spares' components. When ordering, it is advisable to quote the order no. & stock codes under which the instrument was originally purchased, such that it can be confirmed the correct service kit is supplied.

Model 'A'		Model 'B'	
Brass Body	SS Body	Brass Body	SS Body
MNAKN	MNAKP	MNBKN	MNBKP

The above kits include the following components (See Fig 4):

- 1) Diaphragm assembly (A)
- 2) End cover gasket (B)
- 3) Valve seat seal (C)
- 4) Filter (D)
- 5) Filter retaining seal
(x1 on Model 'A', x2 on Model 'B')
- 6) Valve gland packing (E)
- 7) O-ring (J)
- 8) O-ring (K)

RETURNS & WARRANTY

Before returning any goods to RM&C, you must obtain a Returns form containing a unique returns (CA) authorisation number. Failure to do so will result in the goods being returned to you, without any inspection, etc. To obtain this form, contact the QA department of our Sheffield office and by return the form will be faxed to you.

On receipt of the Returns form, fill in any required fields and return it with the goods to the Sheffield office. It is advisable to keep a copy of this form (with authorisation no.) for reference purposes.

If the goods have come in to contact with any processes or environments that may be harmful to a user, then COSHH Regulations must also be observed. It is requested that a Material Safety Data Sheet (MSDS) is also supplied with returned goods, if this is likely to be the case. If not provided and the goods are suspected of being contaminated, they will be returned to you.

On receipt of the appropriate documentation, the goods will be examined and assessed in accordance with the terms of any warranty agreement.

Repairs

Prior to any repair work being carried out, you will be informed of our findings and any charges that may be incurred.

Replacement

Prior to the supply of any replacements, you will be informed of our findings and any charges that may be incurred.

No replacements will be sent prior to receiving the goods back from you, unless an order number is supplied to cover the cost of the new unit/s. After inspection, etc of the returned goods, a credit may be issued, based on our findings.

Warranty (extract from Terms and Conditions)

The warranty period is normally 12 months from the date of shipment, except as agreed at the time of sale.

Any misuse of the goods will void any warranty.

For full warranty and other contract details, refer to our 'Terms & Conditions'.

Every effort has been made during the preparation of this document to ensure the accuracy of statements and specifications. However, we do not accept liability for damage, injury, loss or expense caused by errors or omissions made. We reserve the right to withdraw or amend products or documentation without notice.



LICO Electronics GmbH
 lederinger Strasse 31
 A-2320 Kledering, Austria
 E-mail: sales@lico.at | office@lico.at
 Tel.: +43 1 706 4300

LICO Mechatronic Kft.
 Raba u. 4.
 H-2030 Erd, Hungary
 Email: sales@lico.hu / sales@lico.at
 Tel: +36 23 520 138



CERTIFICATE NO. 22358

www.platon-direct.eu

04HWA0910