

LED Illuminated Magnifier without Dimmer

Interchangeable lens system:

2x	3x	4x	6x	8x	10x	12x	15x
2xAR	3xAR	4xAR	6xAR	8xAR	10xAR		

Select the lens magnification and combine it with the main unit.

Example: **SKKL - F** **2x**  
Series name      Type name      Magnification

**SKKL-F**

- Free arm and clamp type
- Free-type and versatile for inspection, designing, crafting, etc.
- Weight: 2.7kg (Excluding lens)
- Input voltage range:  
AC100 - 240V  
50/60 Hz (125 - 240V is applicable by replacing the input plug. A kind of input plug consult your distributor).
- Power consumption: 10W

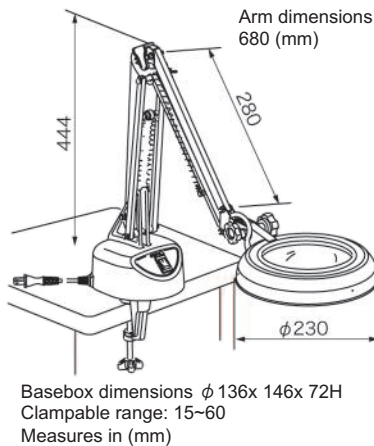
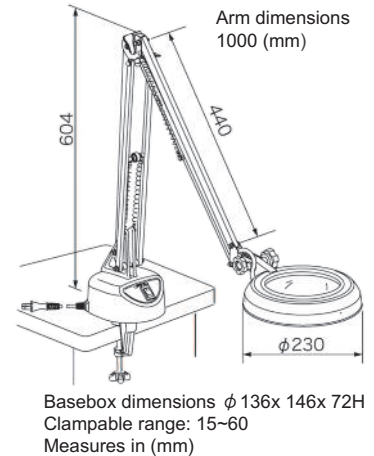

**SKKL-CF**

- Compact free arm and clamp type
- Free-type and versatile for inspection, designing, crafting, etc
- Weight: 2.5kg (Excluding lens)
- Input voltage range:  
AC100 - 240V  
50/60 Hz (125 - 240V is applicable by replacing the input plug. A kind of input plug consult your distributor).
- Power consumption: 10W

**SKKL-FL**

- Free arm with casters stand
- Moveable in the reach of the power cord
- Weight: 12.8kg (Excluding lens)
- Input voltage range:  
AC100 - 240V  
50/60 Hz (125 - 240V is applicable by replacing the input plug. A kind of input plug consult your distributor).
- Power consumption: 10W

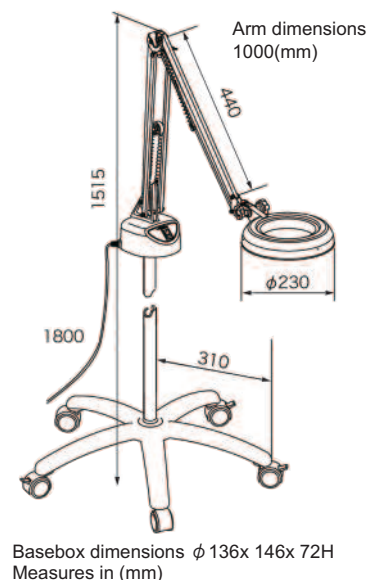

**SKKL-CL**

- Light box with transmission illumination
- Weight: 3.2kg (Excluding lens)
- Input voltage range:  
AC100 - 240V  
50/60 Hz (125 - 240V is applicable by replacing the input plug. A kind of input plug consult your distributor.)
- Power consumption: 10W +5W

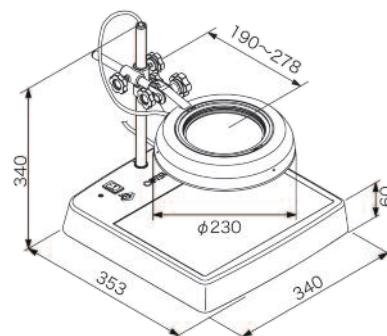

Measures in (mm)

**ENVL - Series** LED Illuminated Magnifier with Dimmer

Interchangeable lens system:



Select the lens magnification and combine it with the main unit.

Example: **ENVL - F** **2x**  
Series name      Type name      Magnification

**ENVL-F**

- Free arm and clamp type
- Free-type and versatile for inspection, designing, crafting, etc
- Weight: 2.8kg (Excluding lens)
- Input voltage range:  
AC100 - 240V  
50/60 Hz (125 - 240V is applicable by replacing the input plug. A kind of input plug consult your distributor).
- Power consumption: 10W
- Light with dimmer(100-50%)

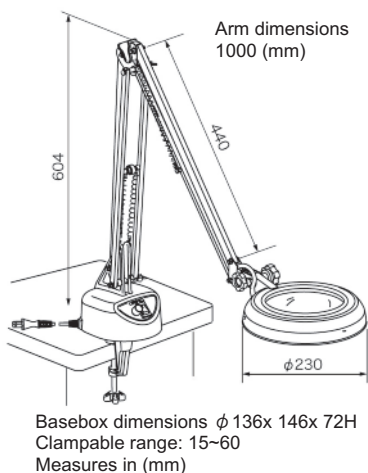

**ENVL-FL**

- Free arm with casters stand
- Moveable in the reach of the power cord
- Weight: 12.8kg (Excluding lens)
- Input voltage range:  
AC100 - 240V  
50/60 Hz (125 - 240V is applicable by replacing the input plug. A kind of input plug consult your distributor.)
- Power consumption: 10W
- Light with dimmer(100-50%)

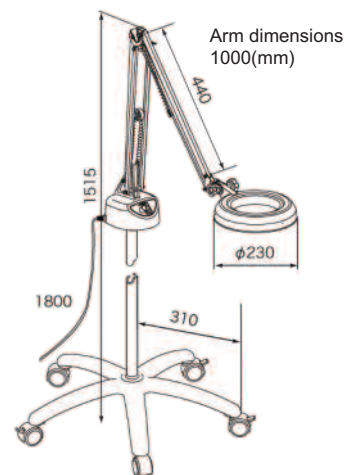

Measures in (mm)