

HD1 heat detector range

Ex d, Ex em & Ex ia

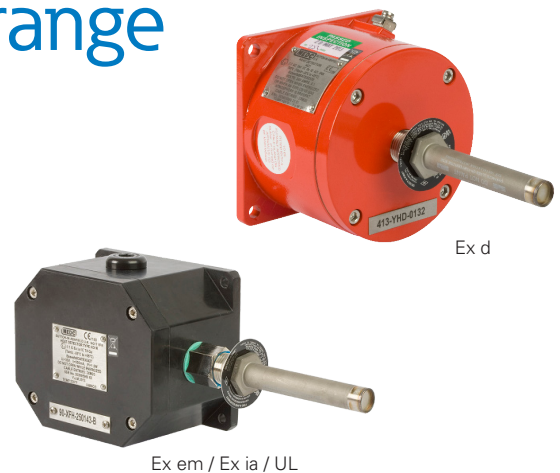

Overview

The Eaton heat detector has been designed for use in hazardous environments. These units are suitable for fire alarm and/or suppression systems in offshore and onshore applications including paint spray booths, flammable material stores, turbine rooms, extract ductwork and other hazardous areas throughout the oil & gas, petrochemical and process industries.

Comprising a Fenwal rate-compensated detector with all-stainless steel external construction, mounted to either a marine grade alloy enclosure (Exd version) or corrosion-free GRP enclosure (Ex ia, Ex em and UL). The contact in the detector CLOSSES at alarm temperature.

To select appropriate temperature setting see specification on reverse.

Features

- Zone 0, Zone 1 and Zone 2 use
- ATEX / IECEx certified
 - Ex d IIB+H2 T3/T6
 - Ex d IIC T4/T6
 - Ex em IIC T4/T6
 - Ex ia IIC T4/T6 Ga
- UL listed for USA and Canada:
 - Class I, Div 2, Groups A, B, C D
- CQST certified
- CCOE certified
- SIL 2 certified
- IP66 & IP67
- Certified temperature:
 - 20°C to +125°C (Ex d)*
 - 20°C to +55°C (Ex em / UL)
 - 55°C to +55°C (Ex ia)
- Stainless steel probe (Ex s)
- Detector temperature settings: 60°C to 385°C, (140°F to 725°F)
- Marine grade alloy or GRP enclosure
- Optional stainless steel guard

*Model dependent



Certifications

ATEX / IECEx EEx d IIB	ATEX cert. no. Baseefa03ATEX0447 IECEX cert. no. IECEX BAS 24.0013X Certified to EN/IEC60079-0, EN/IEC60079-1, EN/IEC60079-31 Ex II 2 GD, Ex db sb IIB+H2 T6 (T3 @ +125C)
ATEX / IECEx Ex d IIC	ATEX cert. no. Baseefa03ATEX0320 IECEX cert. no. IECEX BAS 24.0012X Certified to EN/IEC60079-0, EN/IEC60079-1, EN/IEC60079-31 Ex II 2 GD, Ex db sb IIC T6 (T4 @ +90C)* *+90C not available with addressable module
ATEX / IECEx EEx em	ATEX cert. no. Baseefa03ATEX0428 IECEX cert. no. IECEX BAS 24.0035X Certified to EN50014, EN50019, EN50028 Ex II 2 G, Ex eb sb IIC T6 Gb (-20C to +55C), Ex be em sb IIC T4 Gb (-20C to +55C)* *With resistor fitted
ATEX / IECEx Ex ia	ATEX cert. no. Baseefa03ATEX0427 IECEX cert. no. IECEX BAS 13.0010 Certified to EN/IEC60079-0, EN/IEC60079-11 Ex II 1 G, Ex ia IIC T6 Ga (-55C to +55C)* *T4 with resistor fitted
UL	Listing no. E252920 – versions up to 450°F Listing no. E254077 – versions from 600°F to 725°F UL for USA and Canada, listed to Class 1, Div 2. Groups A, B, C, D
CQST	Certified Ex ia
SIL	SIL2 certified. Cert no. Sira FSP 12007/02

Specifications

Material	Detector: Stainless steel Enclosures: Ex d – LM25 marine grade alloy Ex ia/Ex em/UL – GRP (anti-static) Cover screws: Stainless steel Optional guard: 316 stainless steel
Finish	Detector: Sand blasted. Enclosures: Ex d painted to customers specification Ex ia/Ex em/UL - Natural black or painted to customer's specification
Certified temp	Ex em, UL, Ex d IIC, CQST, Ex d IIB: -20°C to +55°C (T6) -20°C to +90°C (T4) Ex d IIB (Not CQST): -20°C to +125°C (T3) -20°C to +55°C (T6) Ex ia: -20°C to +55°C (T5)* Ex ia: -55°C to +55°C (T6) -55°C to +55°C (T4)* *with resistor fitted
Weight	Ex d, 2kg Ex ia/Ex em/UL, 1.1kg
Ingress protection	IP66 & IP67
Operation	The detector contact is normally open and CLOSSES at alarm temperature
Contact rating	Ex d IIB, Ex em, UL: 125Vac - 5A, 125Vdc - 0.5A, 48Vdc -1A, 24Vdc - 2A Ex d IIC: 24V - 0.1A Ex ia: 30V - 300mA
Entries	2 x M20 (Ex s / Ex em / Ex ia) 2 x ½" NPT via adaptors (UL version)
Terminals	6 x 4mm ² (BK6)
Resistor	Series & EOL resistor (maximum total 2) minimum value (each) 470Ω
Diodes	Up to 2 off available in Ex d IIB, Ex d IIC, Ex ia - contact sales office
Labels	Optional stainless steel tag and duty labels

Ordering requirements

The following code is designed to help in selection of the correct unit. Build up the reference number by inserting the code for each component into the appropriate box

Model

HD1

Certification

Certification	Code
ATEX / IECEx	B
UL listed	UL
ATEX / IECEx / UL triple listed	AU
CQST	Q*

* Only available Ex ia certified. Not for use in China on fire alarm systems

Type

Type	Code
Ex d IIB	BD
Ex d IIC	CD*
Ex em	E†
Ex ia	I‡
UL	U

* Ex d IIC only available in ATEX / IECEx
† ATEX/UL dual listed Ex em version only

Temp settings

Temp°F	Code
140	140
160	160
190	190
210	210
225	225
275	275
325	325
360	360
450	450
500	500
600	600
725	725

Options

Option	Code
None	N
Duty label	I*
Tag label	T*
Guard	G
Resistor EOL	E*††
Resistor series	S*††
Diode(s)	I*††
Blanking plug	P

* Please specify
† Only available in Ex d IIB, Ex d IIC, or Ex ia versions (specify value)
‡ Not available with UL or ATEX/UL or IECEx / UL Dual Listed

Finish

Finish	Code
Natural black	N†
Grey	G
Red	R
Blue	B
Yellow	Y
Special	S*

* Please specify
† Ex em / Ex ia / UL only

General arrangement drawing (all dimensions in mm)

Ex d version

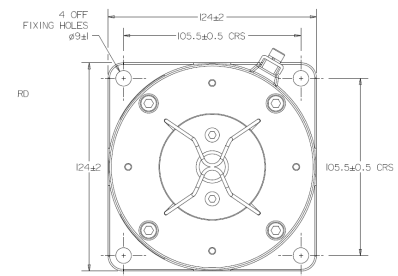
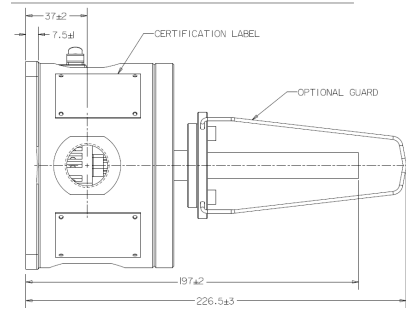

Ex ia / Ex em / UL

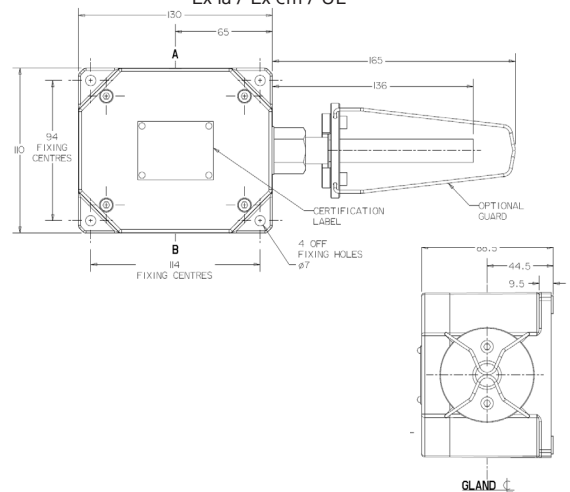

Listed temperature settings: To select appropriate temperature settings, choose detector at 100°F (38°C) above maximum ambient temperature

Temperature setting		Tolerance		Colour code of text on probe
(°F)	(°C)	(°F)	(°C)	
140	60	+7/-8	±4	Black
160	71	+7/-8	±4	Black
190	88	+7/-8	±4	White
210	99	+7/-8	±4	White
225	107	+7/-8	±4	White
275	135	±10	±6	Blue
325	163	±10	±6	Red
360	182	±10	±6	Red
450	323	±15	±8	Green
500	260	±15	±8	Orange
600	316	±20	±11	Orange
725	385	±25	±14	Orange