

# LICO®

[www.prevent-a-fire.eu](http://www.prevent-a-fire.eu)

## LICO HDL ATEX, Certified Heat- & Fire-Detectors

Detect Heat and prevent Overheat, Fire & Explosion

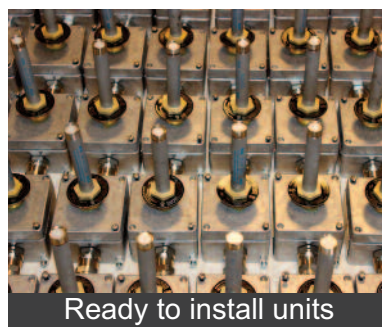

LICO Electronics GmbH  
Klederinger Str. 31,  
A-2320 Kledering, Austria  
Tel: +43 1 706 43 000  
Email: [office@lico.at](mailto:office@lico.at) | [sales@lico.at](mailto:sales@lico.at)



LICO Mechatronic Kft.  
Raba utca 4,  
H-2030 Erd, Hungary  
Tel: +36 23 520 138  
Mobil: +36 30 259 4157  
Email: [sales@lico.hu](mailto:sales@lico.hu) | [sales@lico.at](mailto:sales@lico.at)



## INDEX:

---

LICO HDL ATEX Overview	3
HOW TO ORDER HDL ATEX Ex ia, CATEGORY 1 (ZONE 0 / ZONE 20)	4
HOW TO ORDER HDL ATEX Ex tb, CATEGORY 2 (ZONE 1 / ZONE 21)	6
HOW TO ORDER HDL ATEX Ex d, CATEGORY 2 (ZONE 1 / ZONE 21)	8
HDL-3 & HDL-3XL ATEX Heat- & Fire-Detector Variations	10
HDL-5-ATEX Very High Temperature Heat- & Fire-Detector	11
HDL-3, -3XL & HDL-5 Dimensions	12
HDL-6 & -6XL ATEX Ex d Variations and Applications	13
HDL-7 & -7XL ATEX fully stainless steel Heat Detector Variations	14
Heat Detector Spacing Reduction Based on Ceiling Height	15

### ***Custom made ATEX certified industrial Heat Detector Assemblies from LICO:***



***When there is fire or smoke, its already too late!  
Detect heat before!***

# LICO HDL ATEX Overview

LICO ATEX certified HDL heat detectors are designed and manufactured with the well-known rate-compensated Kidde/Fenwal DAF (Detect-a-Fire) and Ex d certified DAF Sensors. HDL units are mostly custom made and bespoke, designed for the actual hazardous area application.

Products are tested and certified to the possible highest ambient temperature limits, to cover wide range of hazardous area applications as much as possible. Our goal is to over fulfill our customer's expectations and make the right product for the right application.

We mark our ATEX certified HDL products with the following information:



- II 1G Ex ia IIC T6 ... T3 Ga
- II 1D Ex ia IIIC T85°C ... T190°C Da
- II 2G Ex db IIC T6 ... T3 Gb (only HDL6 and HDL6XL)
- II 2D Ex tb IIIC T85°C ... T190°C Db (not applicable for HDL7 and HDL7XL)

### Explanation:

II – Equipment group (I is for mining, II is for surface industry). LICO HDL products are Ex. certified only for surface applications.

1 or 2 or 3 - Equipment category: depending upon Zone of current application. See below table.

G / D: Type of explosive atmosphere: Gas / Dust

ATEX Zone System			
Equipment Category	Zone		Hazardous areas are listed in Zones based on the frequency of duration and occurrence of an explosive Gas/Dust atmosphere, see below:
	Gas	Dust	
1	0	20	Explosive atmosphere is continuously present or for long periods
2	1	21	Explosive atmosphere is likely to occur in normal operation
3	2	22	Explosive atmosphere is not likely to occur in normal operation, but may occur for short periods

**Ex ia:** Describes type of explosion protection

**IIC / IIIC:** Describes II gas group and III dust group

**T6...T3 / T85°C...T190°C:** Describes temperature classification / Details see in the ATEX certificate

**Ga / Da:** Equipment protection level

HDL units are CE marked and meet the requirements of the following EU directives: 2014/34/EU



# HOW TO ORDER HDL ATEX CATEGORY 1 (ZONE 0 / ZONE 20)

## ATEX PROTECTION MARK: Ex ia

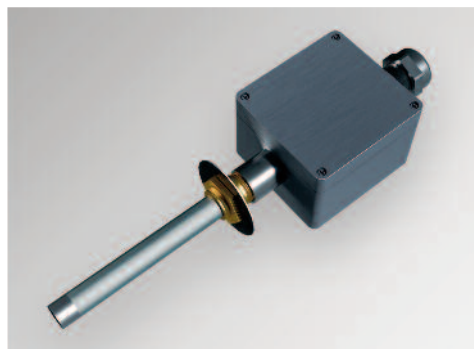

**How to Order / Example:**  
 HDL-3-ATEX-ia-S-1-BR-71-B-S-1-C-1-N  
 HDL-5-ATEX-ia-S-1-ST-232-B-C-2-C-1-E

HDL

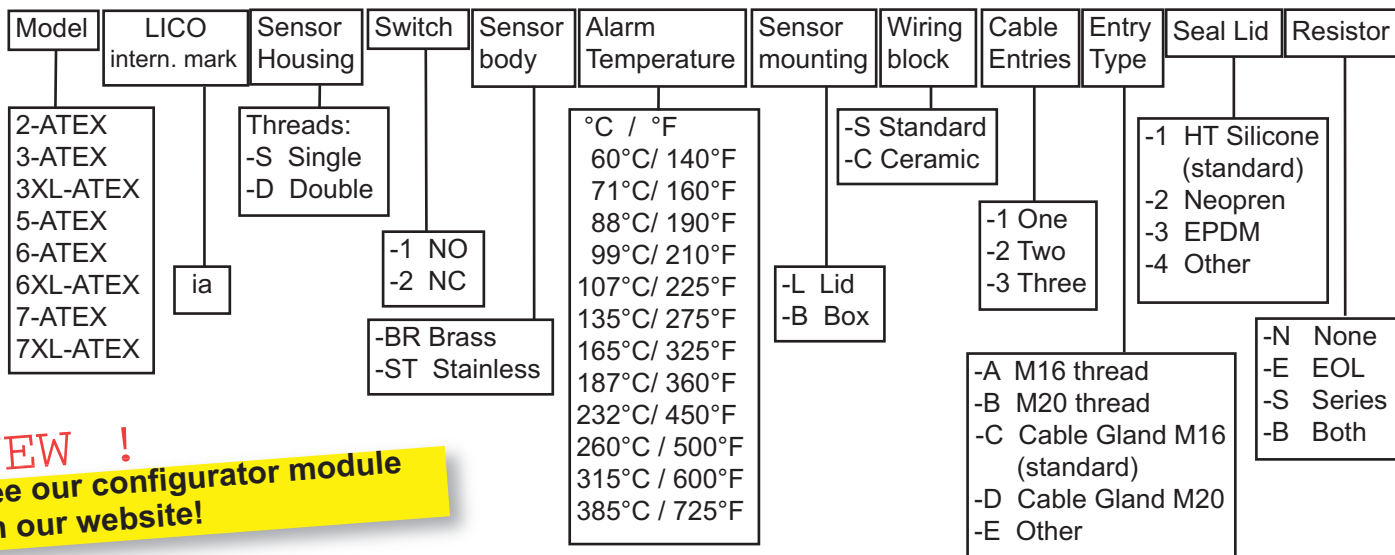

**NEW !**  
 See our configurator module on our website!

### ATEX Protection mark on Ex ia units:



II 1G Ex ia IIC T6 ... T3 Ga  
 II 1D Ex ia IIIC T85°C ... T190°C Da

-Ex i: intrinsic safety (Energy limitation in sparks and hot surfaces) / until Gas Zone 0 and Dust Zone 20

### Ingress Protection on Ex ia units with HDL-6 or HDL-6XL: IP66\*

### Ingress Protection on Ex ia units with HDL-2,-3,-3XL, -5, -7, -7XL: IP67\*

\*IP66/67 ingress protection only with welded, fully stainless steel sensors!

On request:  
 Screw-in-pod



### Restrictions:

1. Only welded, fully stainless steel sensors withstand continuously with IP67.
2. 2 or + Entries recommended only in size HDL3XL and HDL5.
3. Resistors to be mounted in size HDL3-XL and HDL-5.
4. Double thread Sensors are always box mounted as standard
5. Ceramic wiring blocks are available only for HDL-5, HDL-6 and HDL-7 series
6. Standard mounting: if not otherwise specified the sensor would be mounted 180° opposite to the cable entry
7. Above 165°C ceramic wiring terminal blocks are mounted as a standard

intrinsic safety barrier:



### On request:

Sensor protection shells: Weld-in- and Screw-in-pods (Stainless or PTFE or ...)  
 Intrinsic safety barriers, stainless-steel cable glands Serie and/or End of Line Resistors



**LICO Electronics GmbH**  
 Klederinger Str. 31,  
 A-2320 Kledering, Austria  
 Tel: +43 1 706 43 000  
 Email: office@lico.at | sales@lico.at

## SENSOR VARIATIONS FOR CATEGORY 1 (ZONE 0 / ZONE 20)

### ATEX PROTECTION MARK: Ex ia



Single Thread Fenwal DAF Sensors					
2 Wire unit = N/C		4 Wire unit = N/O			
Sensor Housing Stainless Steel		Sensor Housing Stainless Steel			
Body Brass	Body Stainless	Body Brass	Body Stainless	°C	°F
27120-000-140	27120-022-140	27121-000-140	27121-020-140	60	140
27120-000-160	27120-022-160	27121-000-160	27121-020-160	71	160
27120-000-190	27120-022-190	27121-000-190	27121-020-190	88	190
27120-000-210	27120-022-210	27121-000-210	27121-020-210	99	210
27120-000-225	27120-022-225	27121-000-225	27121-020-225	107	225
27120-000-275	27120-022-275	27121-000-275	27121-020-275	135	275
27120-000-325	27120-022-325	27121-000-325	27121-020-325	165	325
27120-000-360	27120-022-360	27121-000-360	27121-020-360	187	360
27120-000-450	27120-022-450	27121-000-450	27121-020-450	232	450
-	-	27121-000-500	27121-020-500	260	500
-	-	27121-000-600	27121-020-600	315	600
-	-	27121-000-725	27121-020-725	385	725



Double Thread Fenwal DAF Sensors					
2 Wire unit = N/C		4 Wire unit = N/O			
Sensor Housing Stainless Steel		Sensor Housing Stainless Steel			
Body Brass	Body Stainless	Body Brass	Body Stainless	°C	°F
-	28020-003-140	-	28021-005-140	60	140
-	28020-003-160	-	28021-005-160	71	160
-	28020-003-190	-	28021-005-190	88	190
-	28020-003-210	-	28021-005-210	99	210
-	28020-003-225	-	28021-005-225	107	225
-	28020-003-275	-	28021-005-275	135	275
-	28020-003-325	-	28021-005-325	165	325
-	28020-003-360	-	28021-005-360	187	360
-	28020-003-450	-	28021-005-450	232	450
-	-	-	28021-005-500	260	500
-	-	-	28021-005-600	315	600
-	-	-	28021-005-725	385	725



#### Attention!

Equipment with Ex i type of protection must be installed with a suitable intrinsic safe barrier / isolator or similar apparatus.

# HOW TO ORDER HDL ATEX CATEGORY 2 (ZONE 1 / ZONE 21)

## ATEX PROTECTION MARK: Ex ia & tb

### How to Order / Example:

HDL-3-ATEX-tb-S-1-ST-71-B-S-1-C-1-N  
HDL-5-ATEX-tb-S-1-ST-232-B-C-2-C-1-E

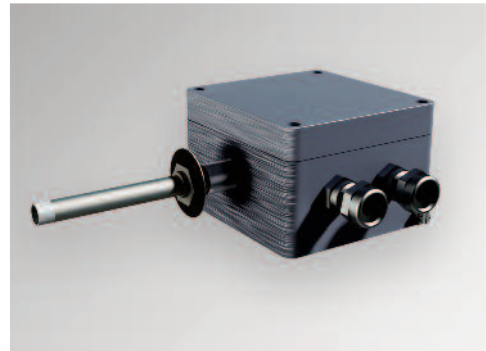

HDL

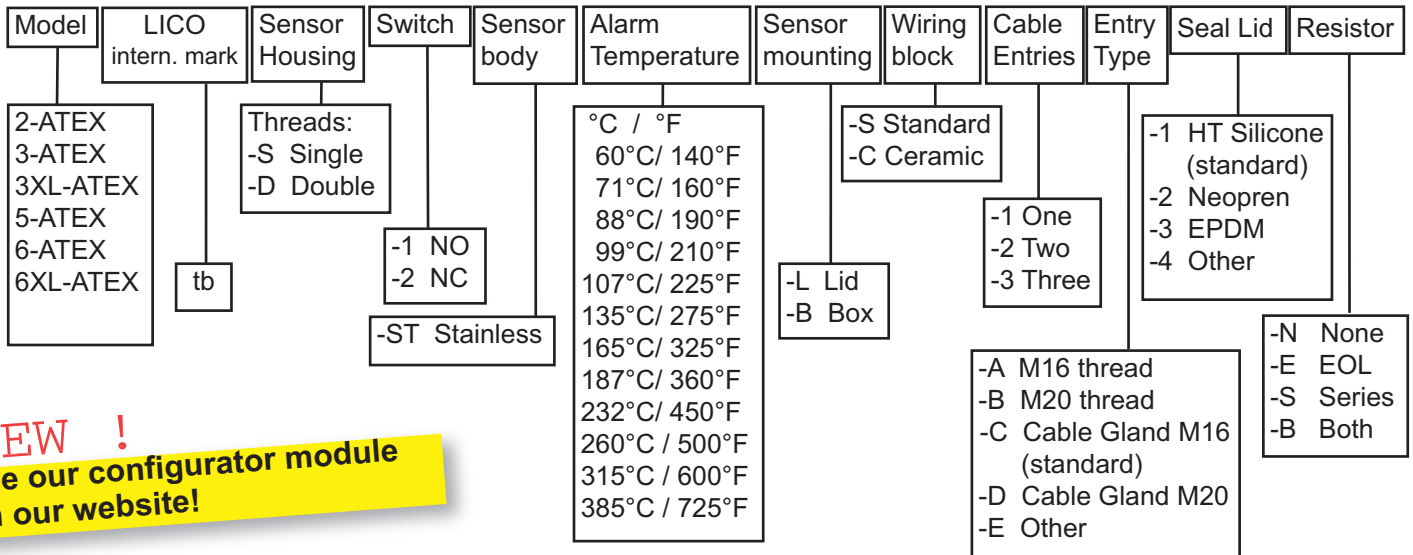

**NEW !**  
See our configurator module on our website!

### ATEX Protection mark on Ex ia & tb units:



II 1G Ex ia IIC T6 ... T3 Ga  
II 1D Ex ia IIIC T85°C ... T190°C Da  
II 2D Ex tb IIIC T85°C ... T190°C Db

-Ex i: intrinsic safety (Energy limitation in sparks and hot surfaces) / until Gas Zone 0 and Dust Zone 20  
-Ex t: protect by Enclosure / until Dust Zone 21

**Ingress Protection on all Ex ia & tb units with HDL-6 or HDL-6XL: IP66**  
**Ingress Protection on all Ex ia & tb units with HDL-2,-3,-3XL, 5: IP67**

**On request:  
Screw-in-pod**

### Restrictions:

1. Only fully stainless steel sensors withstand continuously with IP67.
2. 2 or + Entries recommended only in size HDL3XL and HDL5.
3. Resistors to be mounted in size HDL3-XL and HDL-5.
4. Double thread Sensors are always box mounted as standard
5. Ceramic wiring blocks are available only for HDL-5, HDL-6 and HDL-7 series
6. Standard mounting: if not otherwise specified the sensor would be mounted 180° opposite to the cable entry
7. Above 165°C ceramic wiring terminal blocks are mounted as a standard



**intrinsic safety barrier:**

### On request:

Sensor protection shells: Weld-in- and Screw-in-pods (Stainless or PTFE or ...)  
Intrinsic safety barriers, Stainless-steel cable glands Serie and/or End of Line Resistors



**LICO**®

**LICO Electronics GmbH**  
Klederinger Str. 31,  
A-2320 Kledering, Austria  
Tel: +43 1 706 43 000  
Email: office@lico.at | sales@lico.at

## SENSOR VARIATIONS FOR CATEGORY 2 (ZONE 1 / ZONE 21)

### ATEX PROTECTION MARK: Ex ia & tb



Single Thread Fenwal DAF Sensors					
2 Wire unit = N/C		4 Wire unit = N/O			
Sensor Housing Stainless Steel		Sensor Housing Stainless Steel			
Body Brass	Body Stainless	Body Brass	Body Stainless	°C	°F
-	27120-022-140	-	27121-020-140	60	140
-	27120-022-160	-	27121-020-160	71	160
-	27120-022-190	-	27121-020-190	88	190
-	27120-022-210	-	27121-020-210	99	210
-	27120-022-225	-	27121-020-225	107	225
-	27120-022-275	-	27121-020-275	135	275
-	27120-022-325	-	27121-020-325	165	325
-	27120-022-360	-	27121-020-360	187	360
-	27120-022-450	-	27121-020-450	232	450
-	-	-	27121-020-500	260	500
-	-	-	27121-020-600	315	600
-	-	-	27121-020-725	385	725



Double Thread Fenwal DAF Sensors					
2 Wire unit = N/C		4 Wire unit = N/O			
Sensor Housing Stainless Steel		Sensor Housing Stainless Steel			
Body Brass	Body Stainless	Body Brass	Body Stainless	°C	°F
-	28020-003-140	-	28021-005-140	60	140
-	28020-003-160	-	28021-005-160	71	160
-	28020-003-190	-	28021-005-190	88	190
-	28020-003-210	-	28021-005-210	99	210
-	28020-003-225	-	28021-005-225	107	225
-	28020-003-275	-	28021-005-275	135	275
-	28020-003-325	-	28021-005-325	165	325
-	28020-003-360	-	28021-005-360	187	360
-	28020-003-450	-	28021-005-450	232	450
-	-	-	28021-005-500	260	500
-	-	-	28021-005-600	315	600
-	-	-	28021-005-725	385	725



#### Attention!

Equipment with Ex i type of protection must be installed with a suitable intrinsic safe barrier / isolator or similar apparatus.



## SENSOR VARIATIONS FOR CATEGORY 2 (ZONE 1 / ZONE 21)

ATEX PROTECTION MARK: Ex d

**NEW!**  
Ex d certified DAF Sensors!



Ex d certified, Single Thread Fenwal DAF Sensors					
2 Wire unit = N/C		4 Wire unit = N/O			
Sensor Housing Stainless Steel		Sensor Housing Stainless Steel			
Body Brass	Body Stainless	Body Brass	Body Stainless	°C	°F
-	-	-	27121-215-140	60	140
-	-	-	27121-215-160	71	160
-	-	-	27121-215-190	88	190
-	-	-	27121-215-210	99	210
-	-	-	27121-215-225	107	225
-	-	-	27121-215-275	135	275
-	-	-	27121-215-325	165	325
-	-	-	27121-215-360	187	360
-	-	-	27121-215-450	232	450
-	-	-	27121-215-500	260	500
-	-	-	27121-215-600	315	600
-	-	-	27121-215-725	385	725



### Attention!

Ex d certified heat detector assemblies **must** have Ex d certified sensors, otherwise Ex d certificate can be invalid!



# HDL-2,-3 & HDL-3 XL ATEX Heat- & Fire-Detector Variations:

Commercial & Standard Sauna:

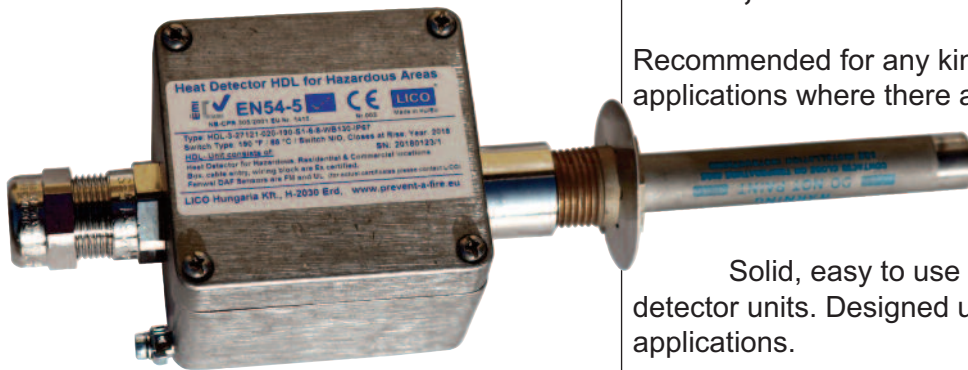

## HDL-2, -3 / HDL-3-XL ATEX:

Recommended for any kind of industrial and commercial applications where there are EN54-5 and/or ATEX/Ex-requirements.

Solid, easy to use & very price economic heat detector units. Designed until 130°C permanent temp. applications.

Sensors are mounted with maximum torque of 27 Nm and sealed with special, high temperature sealant.

Cable glands are mounted & fixed with counter nut and sealed with special, high temperature sealant.

Double thread allows unique through wall installation possibilities using the Detect-A-Fire-Sensor with Coupling Head 28020-215 or 28021-215. The Junction Box may stay at the cooler part of the installation.

### Housing ATEX/IECEX-certified:

- 40°C /+80°C with Neoprene seal,
  - 70°C/+130°C with Silicone-seal,
  - IP67, Internal & external ground-connection
- saltspray-safe, vibration- & shock proven

Wiring Terminal: up to 130°C ATEX/IECEX certification

### Standard ATEX/IECEX certified Cable Gland Variations:

- 20 - + 80°C with Neoprene seal, IP66/68
- 40 - +100°C with EPDM-seal, IP66/68
- 70 - +220°C with Silicone-seal, IP66/68

### Options/ Accessories:

- oil-resistant mounting of Heat Detector and Cable gland
- 2. Cable gland
- Series und EOL – End of Line Resistors
- Very High Temperature Silicone Sealings

## Application:

- Saunas, Power plants, Engine rooms,
- Heating rooms, Air-filter / Duct Systems,
- Chemical plants, Production lines
- Transformer stations, Factories, Kitchens,
- Ceilings, Switch board cabinets etc.

### Individual HDL-3 XL constructions:

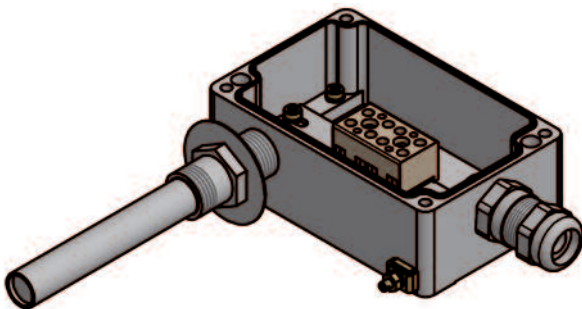

HDL-3 XL with 2 cable glands and single thread sensor 27120-215 or 27121-215

### HDL-3 Standard Size junction box dimensions:

Unit	Outside L. (mm)	Outside W. (mm)	Inside L. (mm)	Inside W. (mm)	Height (mm)
HDL3	80	75	68	63	57
HDL3-XL	80	125	68	113	57

For bespoken, custom made units please contact LICO

# HDL-5-ATEX Very High Temperature Heat- & Fire-Detector

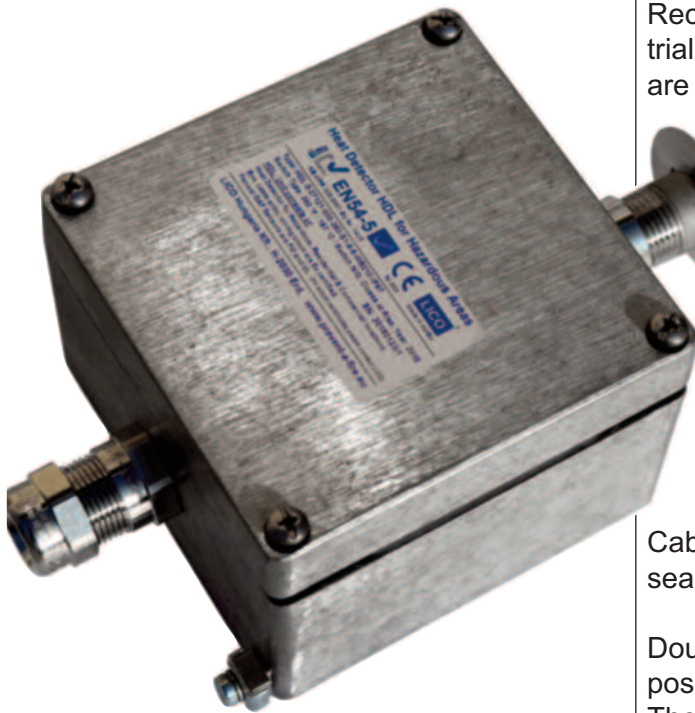

## HDL-5- ATEX:

Recommended for any kind of high temperature industrial and commercial applications where there are EN54-5 and or ATEX/ Ex requirements.

Simply easy, very price economic and reliable Heat & Fire Detector unit. Designed until 220 °C ATEX-certified permanent temperature applications. The real max. operational temperature can be higher.

Sensors are mounted with maximum calibrated torque tool of 27 NM and sealed with special, high temperature sealant.

Cable glands are mounted & fixed with counter nut and sealed with special, high temperature sealant.

Double thread allows unique through wall installation possibilities use with Sensor 28020-215 or 28021-215. The Junction Box may stay at the cooler part of the installation Detect-A-Fire-Sensor with Coupling Head.

### Housing ATEX/IECEX-certified:

- 70°C/+220°C with Silicone-seal, - IP67

### - Ceramic Wiring Terminals: ATEX/IECEX-certified::

ATEX certified until 210°C, max op.temp: >300°C

### Standard ATEX/IECEX Cable gland :

ATEX certified -70 - +220°C with Silicone-seal, IP66/68

### Options/ Accessories:

- oil-resistant mounting of Heat Detector & Cable Gland
- 2. Cable gland
- Cement based ultra high temperature Series and EOL – End of Line Resistors
- Ultra high temperature Silicone Sealings

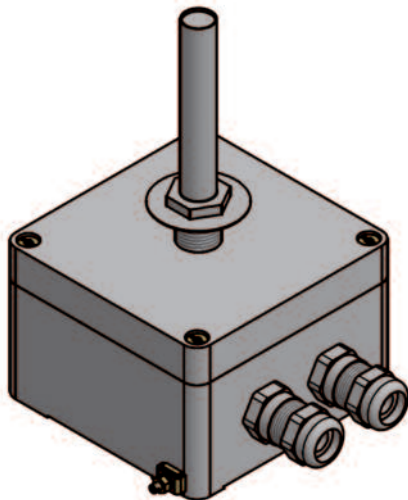
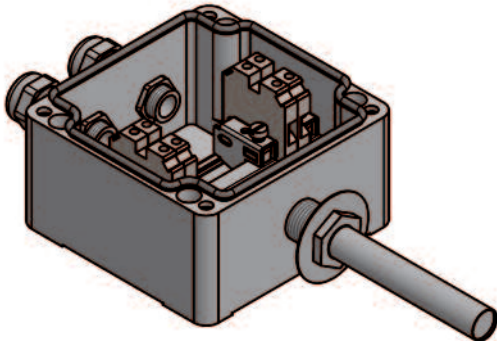

Custom specific HDL-5 constructions

### ***HDL-5 Standard Size junction box dimensions:***

HDL-5	Outside L. (mm)	Outside W. (mm)	Inside L. (mm)	Inside W. (mm)	Height (mm)
Standard	120	122	104	88,5	80

For bespoken, custom made boxes please contact LICO

# Dimensions:

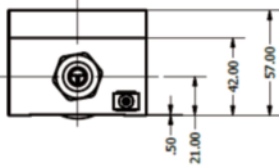

**HDL3**

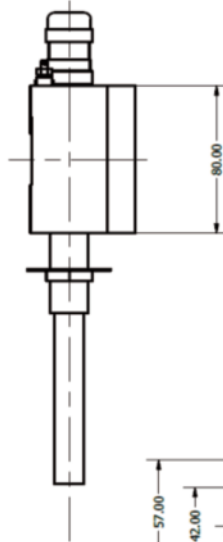
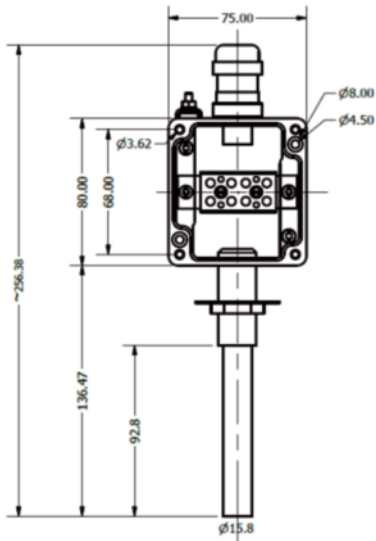

**Weight:**

HDL3: 620g net  
 HDL3XL: 765g net  
 HDL5: 1310 g net

**Custom tariff no.:**  
 8531 1030

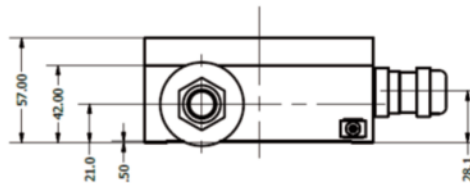

**HDL3XL**

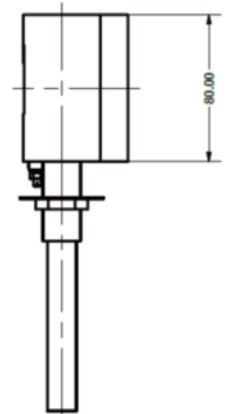
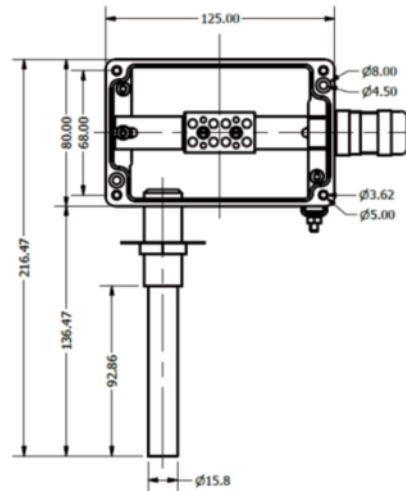

**HDL5**

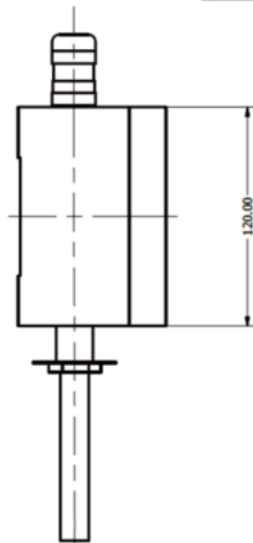
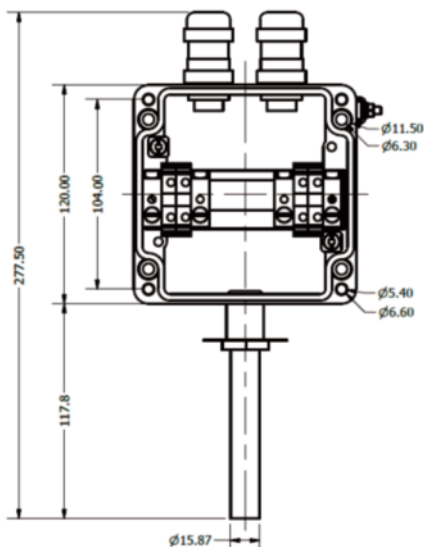
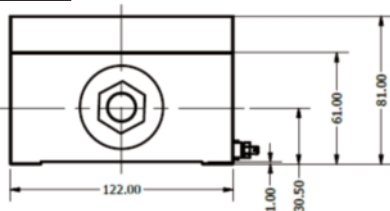

**Disclaimer:**

All the herein given specifications, dimensions, weights, temperatures and tolerances and other values are nominal (typical) and LICO reserves the right to vary all data without prior notice. No liability is accepted for any consequence of use.

# HDL-6 & HDL-6XL Ex d Variations and Applications:

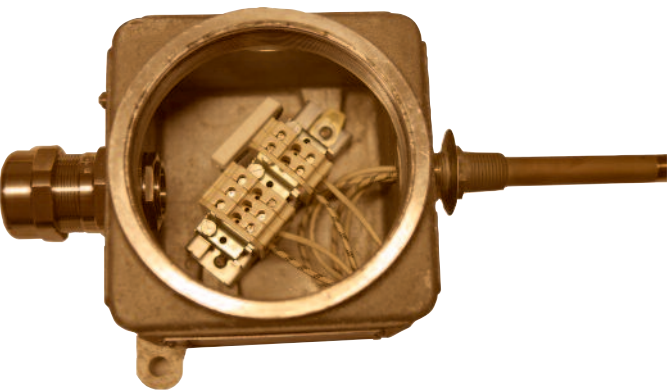

- High temperature, unpainted HDL-6 unit.
- High temperature Ceramic wiring blocks,
- Ultra high temp, Cement based, Ceramic EOL - and Serie Line Resistors



## Painted HDL-6 boxes are:

Chromate primed and polyester powder coated for added protection against corrosion **until 180 °C**

## HDL-6 Ex d:

Recommended for any kind of high temperature industrial and commercial applications where there harsh enviromental & Ex requirements. Designed until 210°C / 220°C applications.

Junction Box may stay at the cooler part of the installation Detect-A-Fire-Sensor with Coupling Head – double thread allows unique installation possibilities, use with Sensor 28020-215 or 28021-215. Proper mounting of box is mandatory to take away stress from the sensor.

Sensors and Cable glands are mounted & fixed with ultra high temperature Loctite seal.

### Housing Ex-certified:

- IP66,
- Wiring Terminal: suitable until 210 °C use acc. Ex requirements

### Standard Ex Cable gland variations:

-70 - +220°C with Silicone-seal, IP66/68

### Options/ Accessories:

- 2. Cable gland (Option KD)
- Cement based ultra high temperature Series and EOL – End of Line Resistors
- Ultra high temperature Silicone Sealings

## **Dimensions & Material:**

Aluminum housing: 165 x 125 x 120 mm,  
Material (Body & cover): Aluminum alloy EN AC-42000 (LM25) to BS EN 1706:1998 with less than 0.2% copper content

Locking Screw: Stainless steel (18/8)

## **Earthing:**

All enclosures are supplied with a 6mm stainless steel (18/8) internal and external earth stud as standard. Larger internal earth terminals can be fitted on request.

## **Protection:**

When fitted with a gasket - IP66

Without gasket - IP54

Application of a non hardening grease to flamepaths and entries is recommended.

## **Applications:**

- Ex 'd' flameproof Applications
- Marine- and Offshore platforms
- Gas-turbine- and Turbine housings, etc.

# HDL-7 & -7XL ATEX fully stainless steel Heat Detector Variations :

## HDL-7 Housing: Standard

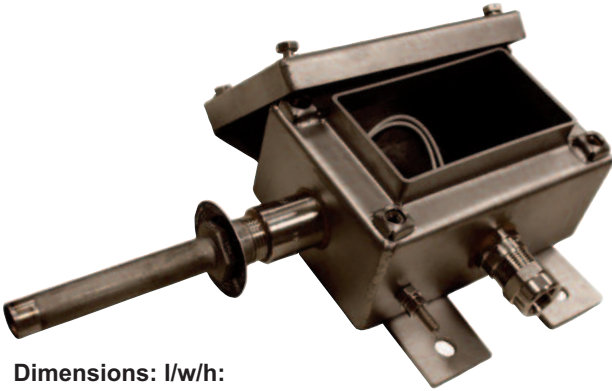

**Dimensions: l/w/h:**  
152 mm, 102 mm, 126 mm  
High Temperature-Silicone-sealing,  
Appropriate stainless steel box,  
Weight: 1500 g  
IP66 or IP67,  
Material: 316(1.4404) or Mild steel

## HDL-7-"FAT BOY" XL Size Housing

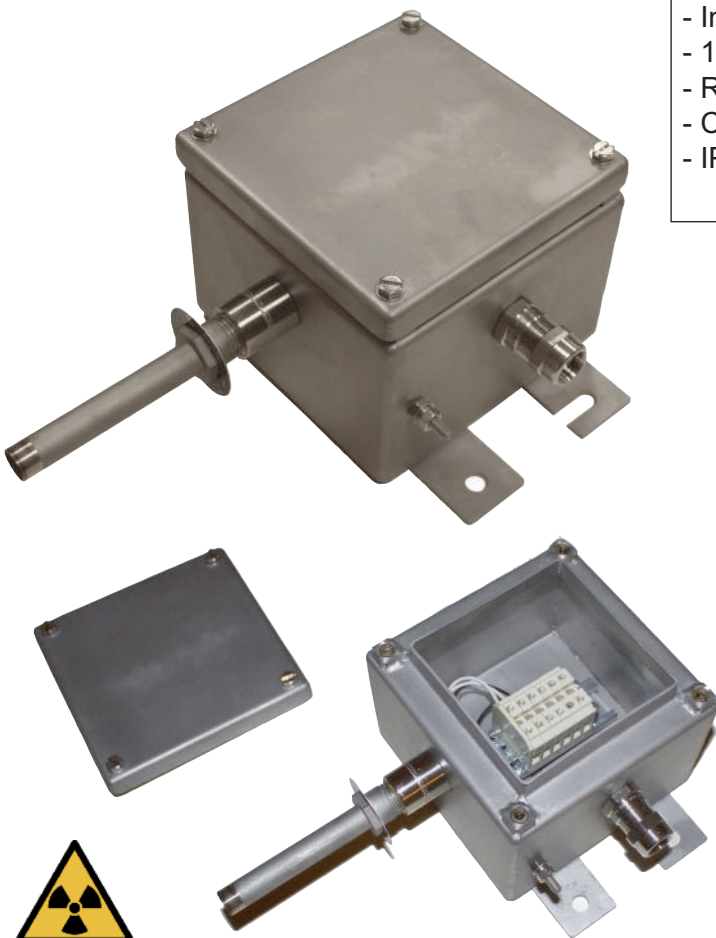

## Radiation Resistant Stainless Steel HDL-7 Heat Detectors

### Stainless Steel "Food Safe" Heat Detector Assembly:

**HDL-7 / Ex: suitable until 210/220 °C max**

\*Ready to install Heat Detector Unit with Bimetallic, **Rate of Rise**, Temperature Sensor mounted in ATEX & IECEX cert. **Stainless steel Junction box**, with ATEX & IECEX cert. Stainless steel cable gland and ATEX & IECEX cert., wiring block assembly. Fully assembled units according to IEC standards.

In other words: Fenwal DAF Sensors mounted in Ex certified Industrial **Stainless steel Box** with Ex certified **Stainless steel** cable glands and Ex certified, high temperature wiring terminals.

- Fenwal-Switch free of Choice
- Stainless steel: 316 (1.4404) or Mild steel
- Sealing: High temp. Silicone, Neoprene on request
- Ex certified box, until 180°C,
- Internal and external ground terminal
- 1 or 2 pcs of stainless steel cable glands
- Removable lid
- Cabling: up to 190°C:Teflon, over 190°C:TGGT
- IP 67

### Food- and Radiation Safe

#### HDL-7 Heat Detectors:

HDL-7 units can be made only with special sealings and radiation proof glue from LICO

### Applications:

- Special areas where aggressive gases and moistures can corrode aluminum or other type of metals
- Food- and Marine Applications
- Highly radiated areas
- Nuclear Power Plants

### HDL-7 "FAT BOY" Dimensions: l/w/h:

152 mm, 152 mm, 126 mm  
High Temperature-Silicone-sealing,  
Appropriate stainless steel box  
Weight: 2200 g  
IP66 or IP67  
Material: 316(1.4404) or Mild steel

# Heat Detector Spacing Reduction Based on Ceiling Height

**Table 1: Model Numbers 27121, 28021, 27120, 28020**

°F Setting	°F Tolerance	°C Setting	°C Tolerance	Spacing (in feet)			RTI	Color Coding
				UL	ULC	FM		
140	+7/-8	60	+4/-5	50	50	20	V-Fast	Black
160	+7/-8	71	+4/-5	25	25	20	V-Fast	Black
190	+7/-8	88	+4/-5	50	50	25	V-Fast	White
210	+7/-8	99	+4/-5	25	50	25	V-Fast	White
225	+7/-8	107	+4/-5	25	50	25	V-Fast	White
275	±10	135	±6	25	50	25	V-Fast	Blue
325	±10	163	±6	50	50	25	V-Fast	Red
360	±10	182	±8	25	50	30	V-Fast	Red
450	±15	232	±10	25	50	30	V-Fast	Green
500	±15	260	±10	50	50	30	V-Fast	Orange
600	±20	316	±12	N/A	50	30	V-Fast	Orange
725	±20	385	±12	N/A	50	30	V-Fast	Orange

**Notes:**  
 • For clean agents or CO2 suppression systems, ceiling spacing is 20ft. apart unless otherwise specified.  
 • For NFPA Guidelines on ceiling height compensation, see Table 7.  
 • \*27120 and 28020 are normally closed devices and do not meet the requirements of NFPA-72 for use as initiating devices (they are 2-wire devices).  
 • \*27120 and 28020 are not listed by FM with RTI.

**Table 2: Vertical D-A-F Specifications**

Model Number	Head Material	Contact Operation	Electrical rating (Resistive Only)
27120-0	Brass	Normally Closed (Open on Rise)	5.0 Amps 125 VAC 0.5 Amps 125 VDC
27120-22	Stainless Steel		
27121-0	Brass	Normally Open (Close on Rise)	5.0 Amps 125 VAC 0.5 Amps 125 VDC 2.0 Amps 24 VDC 1.0 Amps 48 VDC
27121-20	Stainless Steel		
28020-3	Stainless Steel	Normally Closed (Open on Rise)	5.0 Amps 125 VAC 0.5 Amps 125 VDC
28021-5	Stainless Steel	Normally Open (Close on Rise)	5.0 Amps 125 VAC 0.5 Amps 125 VDC 2.0 Amps 24 VDC 1.0 Amps 48 VDC
12-200001-00X*			

Approximate weight: 5 oz. All shell material is Stainless Steel. All Stainless Steel is Type 300. \* Specialty product with limited availability

**Table 5: D-A-F Response Time Index (RTI) and Spacing**

Model No.	Configuration	Contact operation	Temperature (Set Point)	Response Time Index (ft-s) <sup>1/2</sup>	RTI Classification	RTI Rated Spacing	Old Rated Spacing
27021-0	Horizontal Flush Mount	Normally Open (Close on Rise)	140°F (60°C) 160°F (71°C)	110	Quick	(20 x 20) ft (6 x 6) m	(25 x 25) ft (8 x 8) m
27021-1	Horizontal Surface Mount						
27021-0	Horizontal Flush Mount	Normally Open (Close on Rise)	190°F (88°C) 210°F (99°C), 225°F (107°C) 275°F (135°C), 325°F (163°C)	140	Fast	(25 x 25) ft (8 x 8) m	(25 x 25) ft (8 x 8) m
27021-1	Horizontal Surface Mount						
27121-0	Vertical Brass Head	Normally Open (Close on Rise)	140°F (60°C), 160°F (71°C), 190°F (88°C), 210°F (99°C), 225°F (107°C), 275°F (135°C), 325°F (163°C), 360°F (182°C), 450°F (232°C), 500°F (260°C), 600°F (316°C), 725°F (385°C)	99 (140°F, 160°F), 148 (190°F, 210°F, 225°F, 275°F, 325°F, 360°F, 450°F, 500°F, 600°F, 725°F)	V-Fast	(30 x 30) ft (9 x 9) m	(25 x 25) ft (8 x 8) m
27121-20	Vertical Stainless Head						
28021-5	Vertical Stainless Coupling Head						

**Note:** Spaces shown are distances between detectors on smooth ceilings, the distances from partitions or walls would be half that shown. Authority Having Jurisdiction (AHJ) should be consulted before installation.

Above data taken from the original datasheet DETECT-A-FIRE® F-12-0-001 issue June 2020, Vertical & Horizontal Mounting Types on 27.05.2022.



# Custom Made Fire Prevention Solutions from LICO!

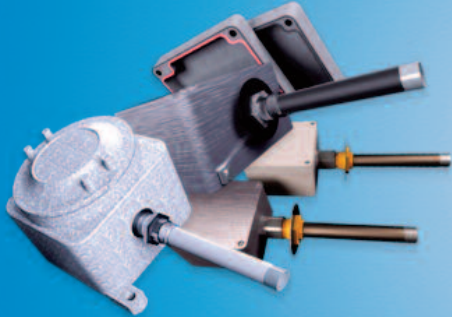

---

*Qualified Trading and Manufacturing of Industrial Electronics*

---

Contact us:

**LICO Electronics GmbH**  
Klederinger Str. 31,  
A-2320 Kledering, Austria  
office@lico.at / sales@lico.at  
Tel: +43 1 706 43 00

**LICO Mechatronic Kft.**  
Raba utca 4,  
H-2030 Erd, Hungary  
sales@lico.hu  
Tel: +36 23 520 113  
Mobil: +36 30 259 4157

[www.prevent-a-fire.eu](http://www.prevent-a-fire.eu)